



Digital Brain for Analog Sound



LAA CUSTOM SMARTSWITCHER
MANUAL

VER. 1.1

CONTENTS

1. Introduction	2
2. Components	3
2.1.1 Overview	3
2.2.1 SmartController	3
2.3.1 Extension.....	3
2.4.1 SmartSwitcher.....	4
2.5.1 App.....	4
3. Detailed Description	5
3.1.1 SmartController	5
3.2.1 Extension.....	5
3.3.1 SmartSwitcher.....	6
4. Audio + Switching Features.....	9
4.1.1. Mono / Dual-Mono / Stereo	9
4.1.2. Four Cable Method (4CM)	10
4.1.3. Buffers.....	11
4.1.4. TrueCoil Output Transformers	11
4.1.5. Fuzz Drivers	11
4.1.6. Wet-Dry.....	12
4.1.7. MIDI	12
4.1.8. MIDI Learn Function.....	13
4.1.9. 1:1 Mixer	14
4.1.10. AUX Switches / Amp switching	14
4.1.11. ISO Loop	15
4.1.12. EXP	16
4.2.1 Wiring Diagrams.....	16
5. Getting Started	19
5.1.1 Downloading the SonicMind® App.....	19
5.2.1 First Steps – Global Settings.....	19
5.3.1 Pedalboard Setup.....	22
5.4.1 Programming - Preset Library	24
5.4.1. MIDI Pedals	26
5.4.2. Editing Presets	27
5.4.3. Song Library	27
5.4.4. Setlist Library	28
6. Performance Modes	29
6.1.1 Presets	29
6.2.1 Setlist	31
6.3.1 Setlist – Customizing Additional Footswitches.....	32
6.4.1 Direct Select	32
7. Care and Maintenance.....	34
8. Specifications	35
9. Safety Notices	36
9.1.1 Warranty	36
9.2.1 Disposal.....	36
9.3.1 Safety	36

1. Introduction

Welcome to your SmartSwitcher! You've chosen what we believe to be the world's best switcher. Not just because it can do so much, but because it's also the easiest and most intuitive switcher to use – thanks to the **SonicMind®** App that is its interface.

We considered NOT writing this manual (do ANY apps have an instruction manual?), but there are still some things that need a little explanation, so here it is!

One feature of the SmartSwitcher is the OTA (Over-the-Air) update feature, which enables the firmware running the SmartSwitcher to be upgraded as we add new features. This means what you have now can only get better and offer you more.

Enjoy!

SonicMind®

SonicMind® is the patented technology we use to power the remote control of the SmartSwitcher and is also the organization behind the **SonicMind® App** that enables the full capabilities of the SmartSwitcher.

In the future a load more gear will be available with SonicMind® inside – and not just from LAA Custom – enabling remote control of pedals and amps as well as switchers like this one.

You can find out more and keep up to date with all that's going on with SonicMind here:

<https://sonicmind.net/>

This means that your SmartSwitcher is also the beating heart of a revolution and you are ready to get the best out of it!

2. Components

2.1.1 Overview

The LAA Custom SmartSwitcher is a new concept in the world of guitar gear. A world-leading switcher that is controlled through a remote footswitch unit and configured and monitored with an intuitive app.

The tone path remains 100% analog and (without the need for footswitches on the SmartSwitcher itself) it is compact-enough to fit under the pedals in most pedalboards, or even in a rack.

The switcher unit is controlled through a remote footswitch unit (SmartController), which communicates with the SmartSwitcher via radio frequency.

The intuitive SonicMind® App (Android or iOS) enables all required set-up and programming.

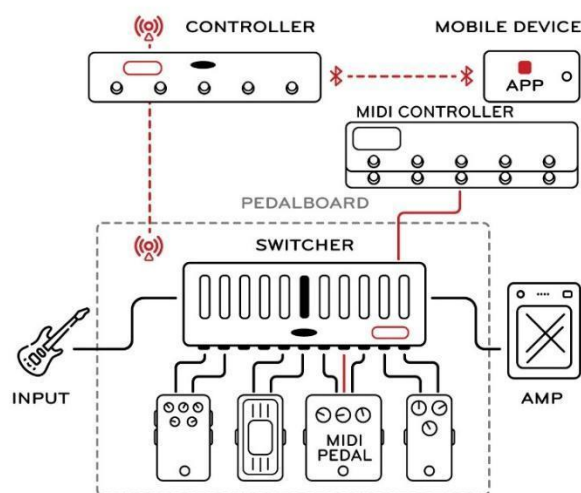

2.2.1 SmartController

The SmartController is the 5-footswitch floor unit that enables control of the SmartSwitcher. It operates wirelessly over sub-gigahertz radio frequency. Its compact size enables it to be fitted at the front of your pedalboard, or most likely, used outside the pedalboard. It also acts as the communications bridge between the app and the SmartSwitcher.

The five footswitches are bankable and can be assigned any number of functions through the app.

It is completely wireless, meaning that, in addition to the RF remote-control, it is also battery powered. It uses 6 x AAA 1.5V batteries which can be standard or rechargeable, with a 9V power supply available on the end of the SmartController, which is also used for recharging.

When using rechargeable batteries, the expected battery life is 8-10 hours. Depending on the make and quality, rechargeable batteries generally need replacing after 3-4 years of normal use.

In addition, the SmartController can be connected to the SmartSwitcher via an RJ45 (ethernet) cable, in which case, the power supply comes from the SmartSwitcher and the batteries are not used.

2.3.1 Extension

In many cases, five switches are not enough to do all you may want to do with your SmartSwitcher, so, to enable all different modes in which you may want to use your SmartSwitcher, we have also made it possible to add a 5-switch extension. The extension unit is plug-and-play – simply plug it together with the SmartController via the 9-pin D-sub mating connectors on the SmartController and

extension, and it will self-identify and automatically add the additional switches in the app. All functionality available on the SmartController footswitches is available on the extension unit. The extension unit is also powered from the SmartController. Since the extension uses so little power, its effect on the SmartController's battery life is negligible.

2.4.1 SmartSwitcher

The SmartSwitcher enables the sequence of all connected pedals to be interchanged in multiple ways as well as having additional functions such as expression pedal support, MIDI In, MIDI Out, buffers and AUX switches. It does this without ever digitizing the analog signal path. The tone is always left as 100% pure analog.

Because it has been designed to be without footswitches and operator controls, we have been able to make the switcher unit as small as possible. This means that it takes up the minimum space on your pedalboard, in many cases, you'll be able to stow the SmartSwitcher away underneath your pedals. In addition, we provide 2 mounting brackets that can be fixed to either end of the SmartSwitcher and will enable it to be mounted in a standard 19" rack.

The SmartSwitcher utilizes an external power supply of 12VDC @ 500mA – which you may already have on your pedalboard.

2.5.1 App

The **SonicMind® App** is the user interface for the SmartSwitcher and enables all of the programming of presets and their utilization in the various performance modes. The interface is designed to be as simple and intuitive as possible. The App also enables you to safely back up and save all of your settings.

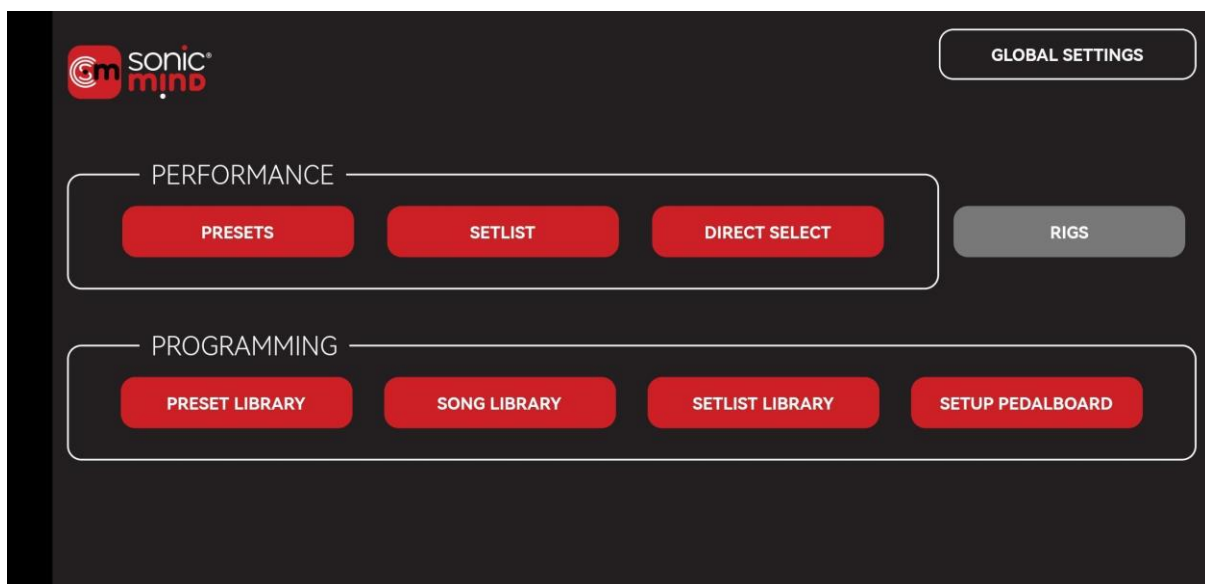

3. Detailed Description

3.1.1 SmartController

The SmartController is a stand-alone, wireless-controlled unit that communicates with the SmartSwitcher via RF, and with the APP via Bluetooth®. It also has the possibility of being connected to the SmartSwitcher via RJ45 (ethernet) cable. In this case, the SmartController will be powered from the SmartSwitcher.

To power the SmartController **on**, press and release the RED power button on the left end-panel of the SmartController. LED A will shine GREEN, and then start to blink BLUE - indicating it is searching for a Bluetooth® connection to your Android or iOS device to initiate communication with the SonicMind® APP.

To power the SmartController **off**, press the RED power button for 2 seconds then release.

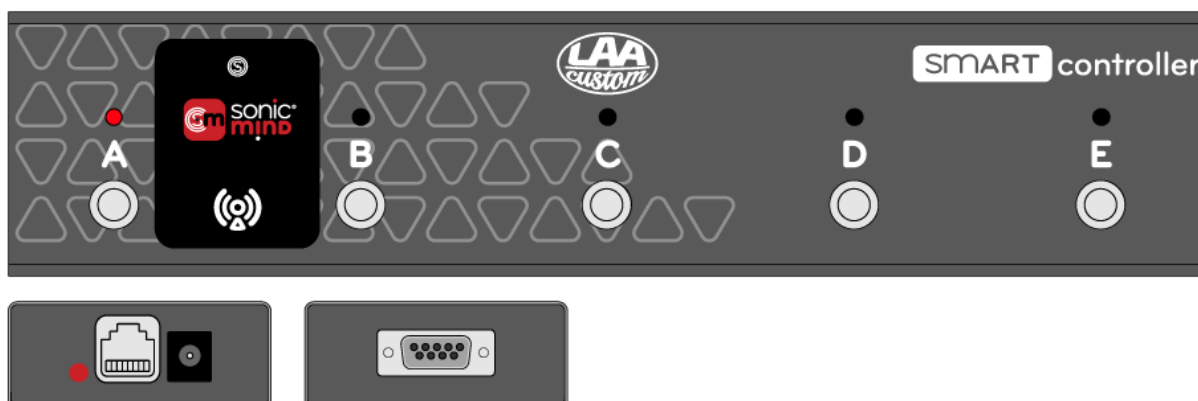

Dimensions: 300x66x35 mm

Power: To recharge the batteries - **9V @ 300mA**. Standard 2.1 9V connector with **center negative pin**

Connection: RF/Ethernet RJ45

When the SmartController is connected to the SmartSwitcher via RJ45 cable, we recommend that the 9V power supply is NOT connected at the same time.

Use non-rechargeable batteries only in emergencies, and in such cases, do NOT use a power supply!

3.2.1 Extension

The Extension unit connects to the SmartController via a male/female VGA connector located on the left end-panel of the unit. The male/female connections of the 2 units enable them to “plug together” to form a single unit.

We recommend fixing the units to a stable surface using Velcro or an L clip to avoid any poor contact arising during use.

If you wish to have the 2 elements located a distance apart, or even forming a 2x5 switch block, then it is also possible to use a standard male-female VGA connection cable to connect the two elements.

There is no power button for the extension. If it is connected to a SmartController, when you power the SmartController up, the Extension unit is powered immediately.

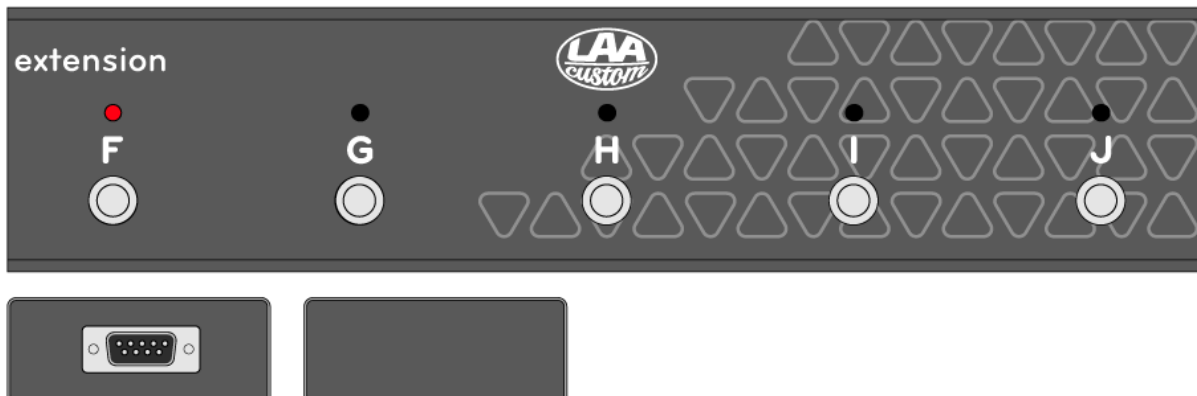

Dimensions: 300x66x35 mm

Power: The Extension unit is powered through the serial connection with the SmartController.

3.3.1 SmartSwitcher

FRONT



Inputs

There are two input jacks to connect your instrument to the SmartSwitcher, one on the front panel (marked **INPUT**), the other on the back panel (marked **IN**). The front connector is generally only used when the Smartswitcher is rack-mounted. Using the front input, automatically disables the connector on the back panel.



On the front panel, next to the input, there is also an input sensitivity control.

For **instrument level** input, set it to **LOW**. For **line level** input, set it to **HIGH**.

Cable connection to SmartController

Should you want to connect the SmartController and SmartSwitcher without using RF, then the RJ45 cable connects to the socket marked **CBL** on the front of the SmartController.

Mini Switches

Also on the front panel, there are 7 sets of slide switches. These are designed to be easily changed (using the tip of a pick). These are used for setting the input sensitivity, phase polarity, boost for fuzz pedals and ground lift for the outputs. Their detailed functions are explained later in Section [Fuzz Drivers](#).

BACK

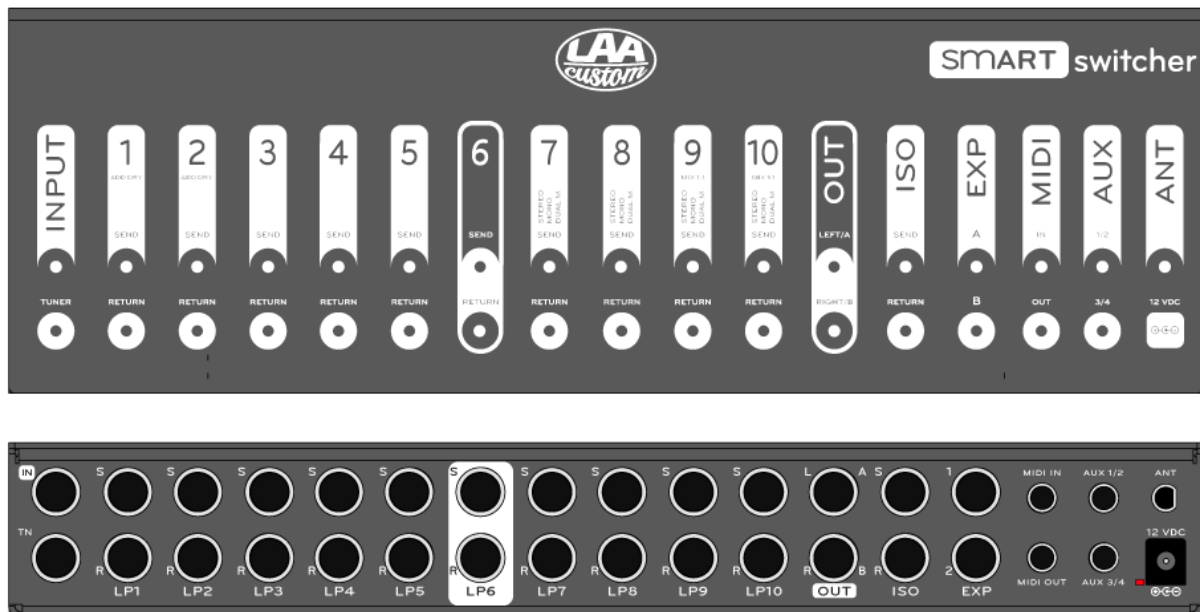

The input/output jacks of the SmartSwitcher are located on the back panel. This is where you connect your pedals, AUX switching and MIDI in/out.

Loops 1 to 6 are mono.

If you wish to use 4CM cable wiring, then Loop 6 must be used for this (Note: the position of any connected effect, and also the position of the 4CM loop, in your signal chain can still be freely programmed in the App for each preset).

Loops 7 to 10 are capable of operating in Mono, Dual-Mono or Stereo modes.

Loops 9 and 10 can also use the 1:1 internal line mixer. This enables the dry signal to be kept analog when using digital pedals with the possibility to apply a “kill dry” option.

Outputs

The Outputs can work as A/B/Y in Mono or Dual-Mono or Left and Right if stereo pedals are used. Both outputs are isolated by custom output transformers. In the event of there being any hum, use the two ground-lift switches on the front panel. The default position is with the slide switch to the left, GDN. In the event of any ground loops, switch to LIFT.



ISO Loop

There is an isolation 1:1 transformer in the ISO Loop. This can be used in those cases where a ground loop occurs, for example when using the 4CM wiring method.

EXP

These connections are used to connect an expression pedal using 1/4” TRS cable. The TRS cable must be connected before supplying power to the Smartswitcher. Refer to Section [4.1.12 EXP](#) of this manual for cabling.

MIDI IN/OUT

The MIDI IN connector receives the MIDI signal from any external MIDI device.

The MIDI OUT connector is used to send MIDI signals to external MIDI devices. Refer to Section [4.1.7 MIDI](#) of this manual for cabling.

ANT

To ensure consistently-reliable RF communication with the SmartController, we recommend connecting the external booster antenna here. If your SmartSwitcher is rack-mounted, use the extension cable provided to move the antenna socket onto the rack mounting lugs.

Power Supply

For the best performance, with ample headroom for all your gear, we recommend you use a well-filtered 12V DC power supply with a 500mA current capability.

Tuner Output

For an output to a tuner, connect to the TN socket. A signal is always present here, even in MUTE mode.

WARNING: Ensure and check that all external cables are correctly wired to the SmartSwitcher before powering the system up.

Rack mounting

Since the SmartSwitcher is controlled remotely from the SmartController, it can be fitted conveniently into a rack-mounting system. For this, each SmartSwitcher comes with rack-mounting lugs. To add these, simply screw the two different lugs (short and long) onto the appropriate ends of the SmartSwitcher using the tapped holes provided.

4. Audio + Switching Features

4.1.1. Mono / Dual-Mono / Stereo

The SmartSwitcher is capable of managing 6 mono pedals (Loops 1 to 6) and 4 stereo pedals (Loops 7 to 10). However, from the App, the user can set the stereo loops as mono, dual-mono or stereo. Dual-Mono means that for every stereo loop you are able to connect and manage two effects independently using a TRS connector and custom Y wiring.

DUAL-MONO

The cabling for the dual-mono functionality is configured as follows.

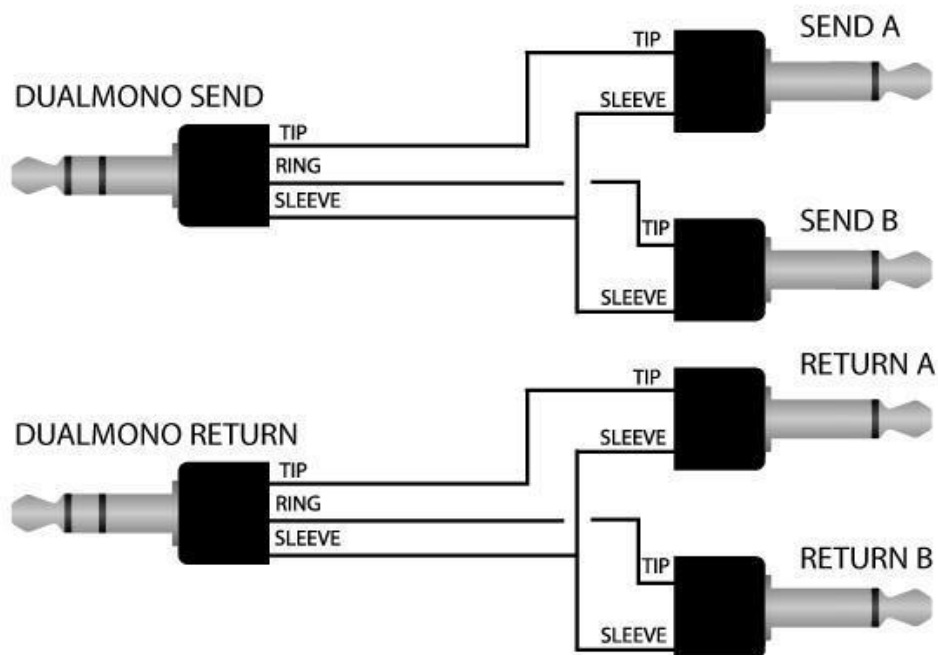

TIP is for FxA; RING for FxB and the SLEEVE is the common ground reference.

When any of Loops 7 to 10 are used with TRS-connected mono effects, the loop numbering for them follows the following logic:

- Loop 7A (connected to Tip)
- Loop 7B (connected to Ring)

This is also reflected in the App as shown here.

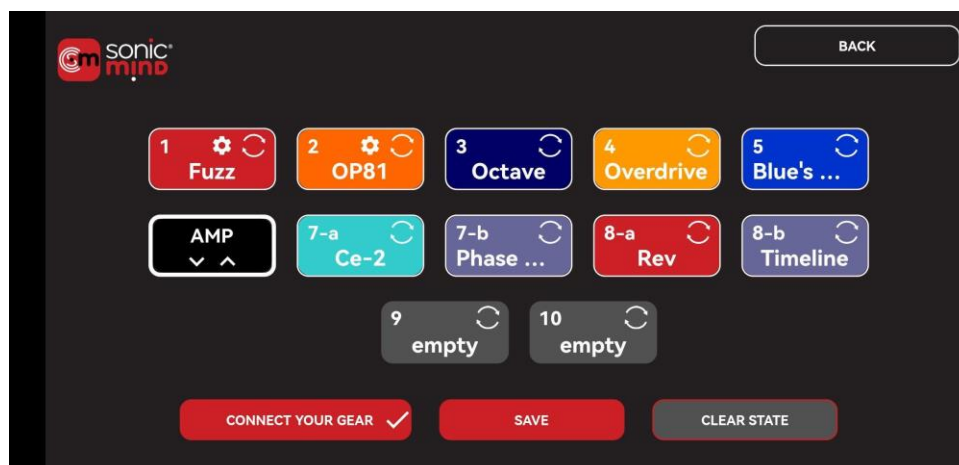

STEREO

For Stereo effects, the cable wiring is made as shown below

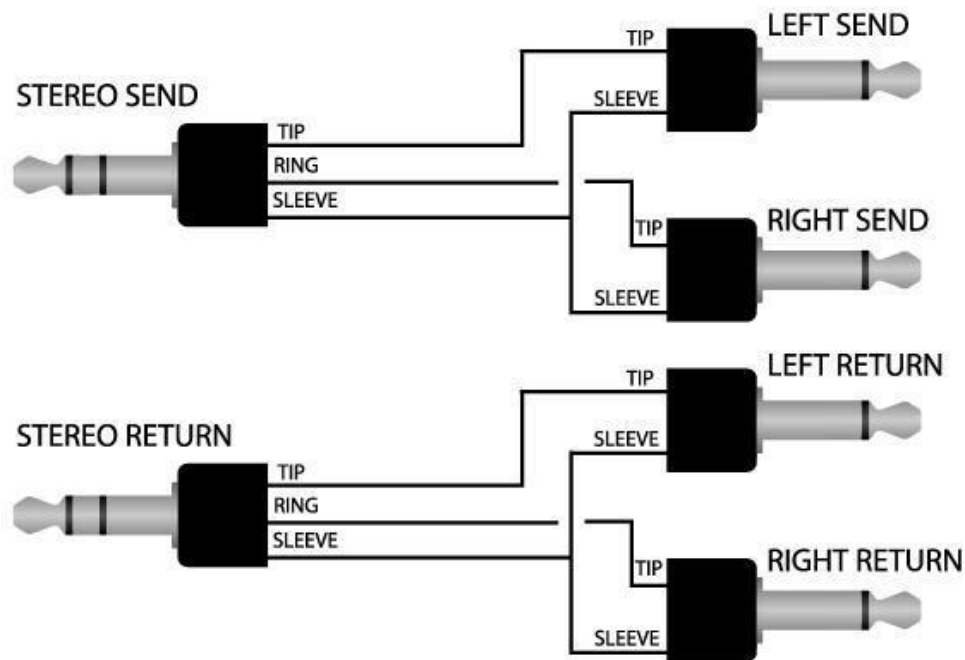

4.1.2. Four Cable Method (4CM)

The SmartSwitcher enables you major flexibility in how you connect your pedalboard and your amp using it's Send/Return loop. To use 4CM wiring you will need to "sacrifice" Loop 6.

You will connect Loop 6 SEND to the amplifier input, and connect the amplifiers Send to Loop 6 RETURN. The output A or B goes to amplifier Return. To ensure that the signal remains strong and clear, Loop 6 has 2 dedicated buffers.

Of course, this is just for the physical connection of the effects and amp to the SmartSwitcher terminals... the actual order of your effects, and how many are before or after the amp, is freely programmable for each preset! Thus, you can move any connected pedals in front of the amp or into the effects loop of the amp for each preset. How? Simple - with drag and drop on the App when you're creating your preset.

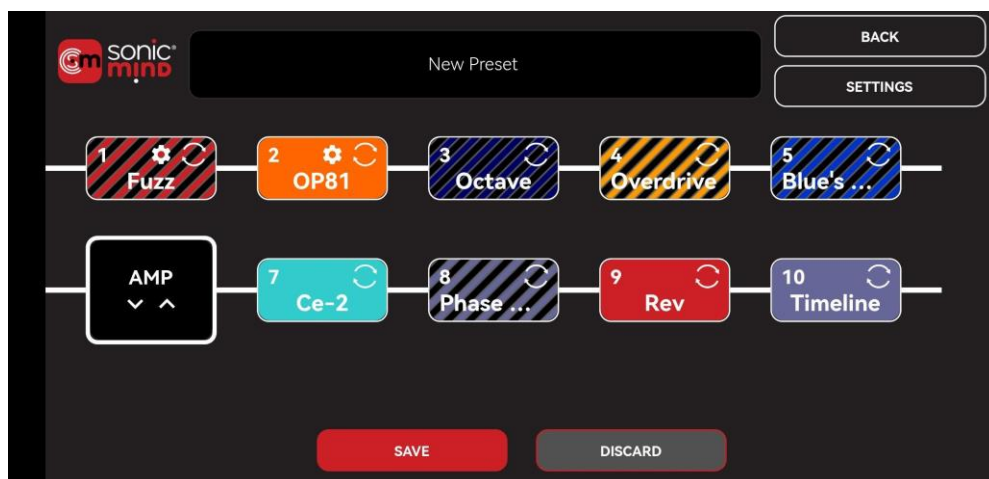

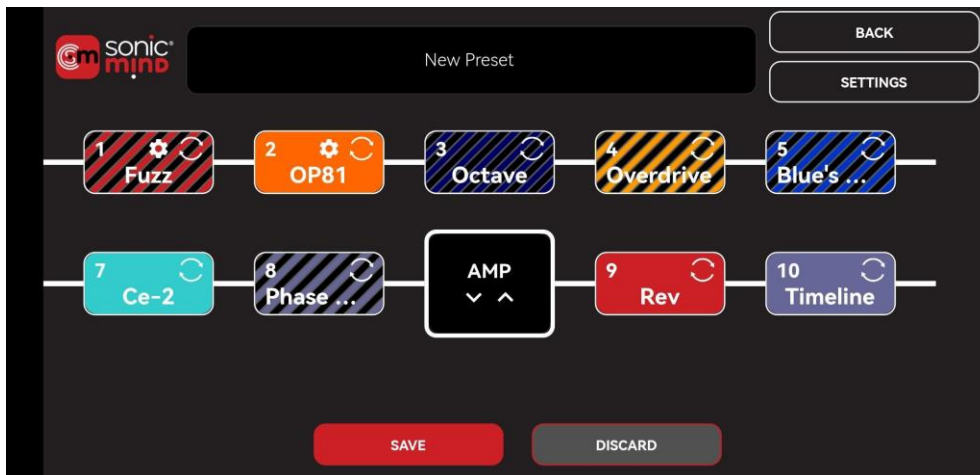

4.1.3. Buffers

The SmartSwitcher features 5 buffers. There is one buffer at the input, one at Loop 6 Send, one at Loop 6 Return and then two in the output stage - one buffer for each output driving the TrueCoil output transformers. The output buffers are effectively transformer drivers as they've been designed to keep the original signal untouched, in terms of frequency and dynamic response - managing the output level and boost for those channels. For this they run at 12VDC with dual rail, meaning 24VDC in total, so lots of headroom.

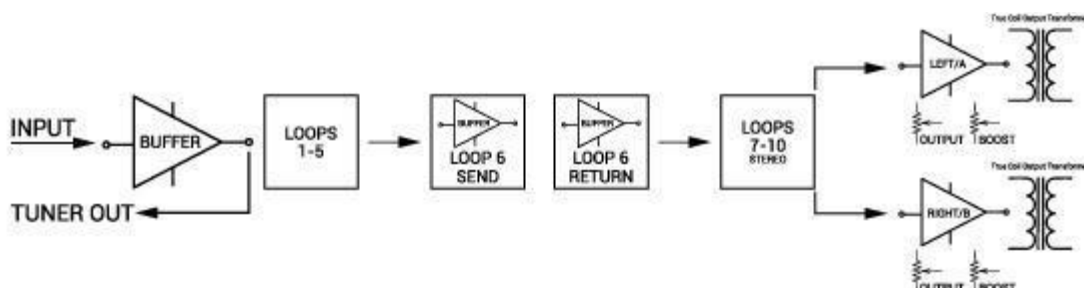

4.1.4. TrueCoil Output Transformers

In designing the SmartSwitcher, the goal was to have the best signal management whilst maintaining the best tone.

The SmartSwitcher uses LAA Custom's unique TRUE COIL technology - directly derived from studio gear. Output transformers are a great way to interface signals with long cables without losing any signal or dynamic. In addition, they are useful for balanced output - and with the Ground Lift, it kills any ground loop noise when using two different amps.

4.1.5. Fuzz Drivers

Since we know that Fuzz pedals don't react well to buffers in front of them, we've added a hidden feature to Loops 1 & 2. Loops 1 & 2 therefore feature a high-impedance driver with a 3dB gain step (selectable on the front of the SmartSwitcher) which can be activated when you attach a Fuzz pedal to either of these two loops.

Since some pedals may have the output signal out of phase with reference to the input, a PHASE switch is also available on the SmartSwitcher input.

Phase switch can be also an interesting creative tool for your tone. When you merge some Dry signal, follow your senses to choose the best position for the phase switch.

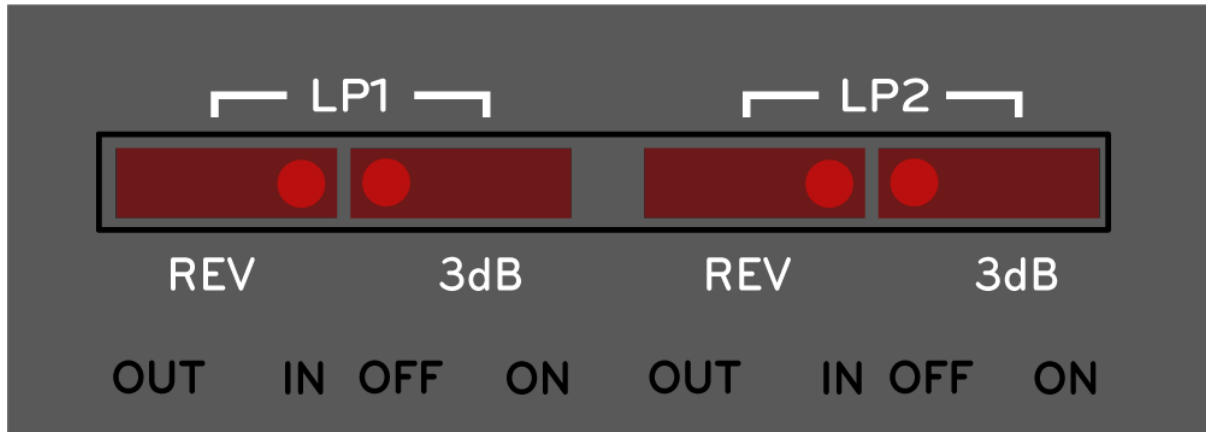

The position of switches as shown indicates the default state.

4.1.6. Wet-Dry

On Loops 1 & 2 there is the possibility of merging a level of DRY signal to the effect.

Perhaps you want your Compressor without the BLEND or you'd like to have some DRY added to your Overdrive pedal – this can be done, simply by adjusting the right amount of DRY signal within the App.

4.1.7. MIDI

The SmartSwitcher is fully MIDI compatible, featuring both MIDI IN and MIDI OUT capabilities.

Through the MIDI IN connection, it can receive Program and Control Change commands from an external MIDI pedalboard to recall presets of specific functions.

It is also possible to send up to 8 MIDI messages (PG and CC) on different channels for each preset.

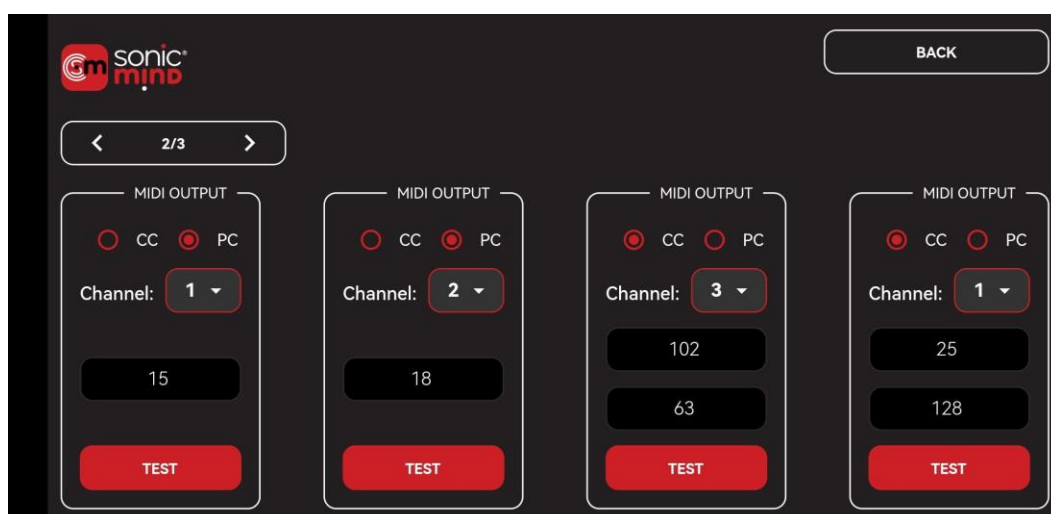

We use a TRS mini jack as MIDI IN and MIDI OUT connectors - Type A TRS-DIN5 cable for the MIDI IN and Type B TRS-DIN5 cable for MIDI OUT.

MIDI IN

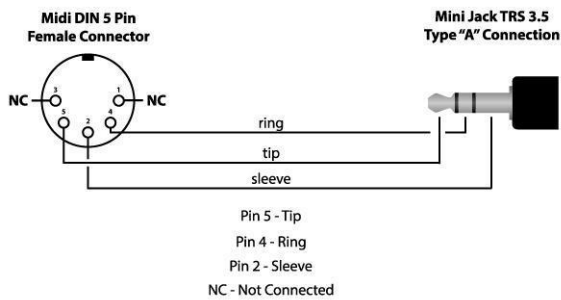

MIDI OUT

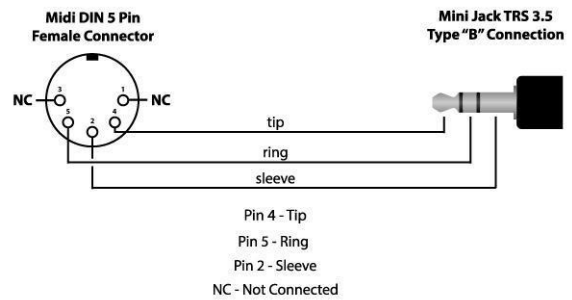

In addition, we're also working towards including the MIDI profiles for a significant number of MIDI-capable pedals. Currently, these do not have standardized MIDI commands (almost each unit is different) and must be added individually to the library. The MIDI pedals added will all be programmable by simple knobs and sliders within the app, without any need for you to refer to the manuals or MIDI command sets – it will all be done by the app in the background. As more MIDI devices are added, they will be included in the "over-the-air" updates, so no SmartSwitcher owner will ever be left behind.

4.1.8. MIDI Learn Function

We have also added another feature for those who use MIDI controllers or who want the SmartSwitcher to receive MIDI commands from other devices - the "MIDI LEARN" function. This effectively enables you to configure a preset and then assign a MIDI command to it. The process for this is as follows: once you have configured the preset, press the "MIDI LEARN" button on the "Edit Preset" screen in the app. This puts the SmartSwitcher MIDI input into a listening mode. Then send the command that you wish to assign the preset to from your MIDI control device to the SmartSwitcher.

That's it... the incoming MIDI command is assigned to that particular preset and that preset will be recalled whenever that command is sent to the MIDI input of the SmartSwitcher.

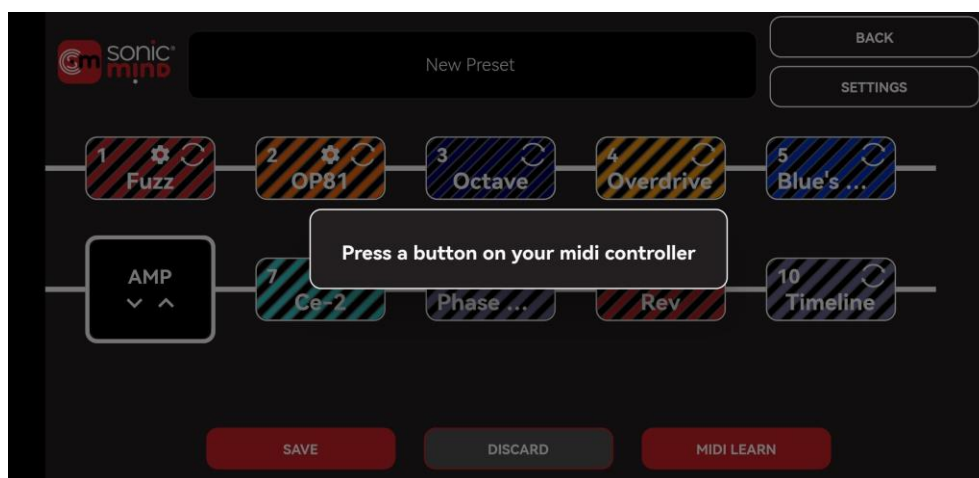

4.1.9. 1:1 Mixer

On Loops 9 & 10 (stereo or mono/dual-mono selectable) there is a 1:1 line mixer. Since many digital pedals are used for Delay or Ambient effects, if you want to keep the DRY signal analog you can enable the “kill dry” mode in the digital pedal and then just add the WET. This will enhance your tone without any A/D/A conversion of your DRY signal and also enables spillover between presets. To enable this function, you should activate it in the Global Settings from the APP.

4.1.10. AUX Switches / Amp switching

The SmartSwitcher features 4 clean AUX contacts. These can be used for switching amp channels or, in fact, any guitar gear that uses TRS cable for switching. The switches can be set to be latched or momentary as their polarity (normally-open or normally-closed) from within the APP.

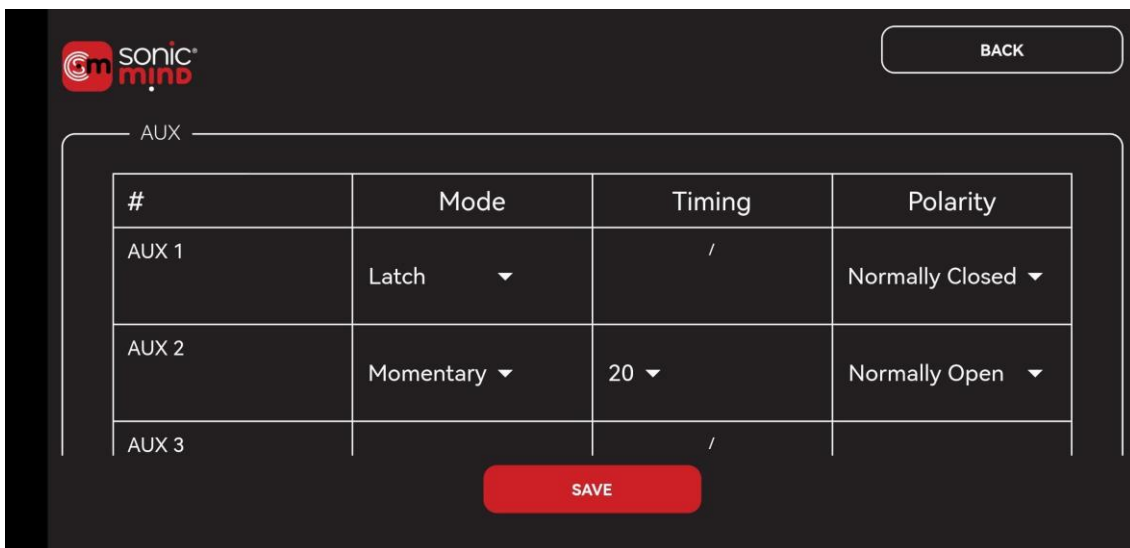

Follow this scheme for the wiring of the AUX Switches:

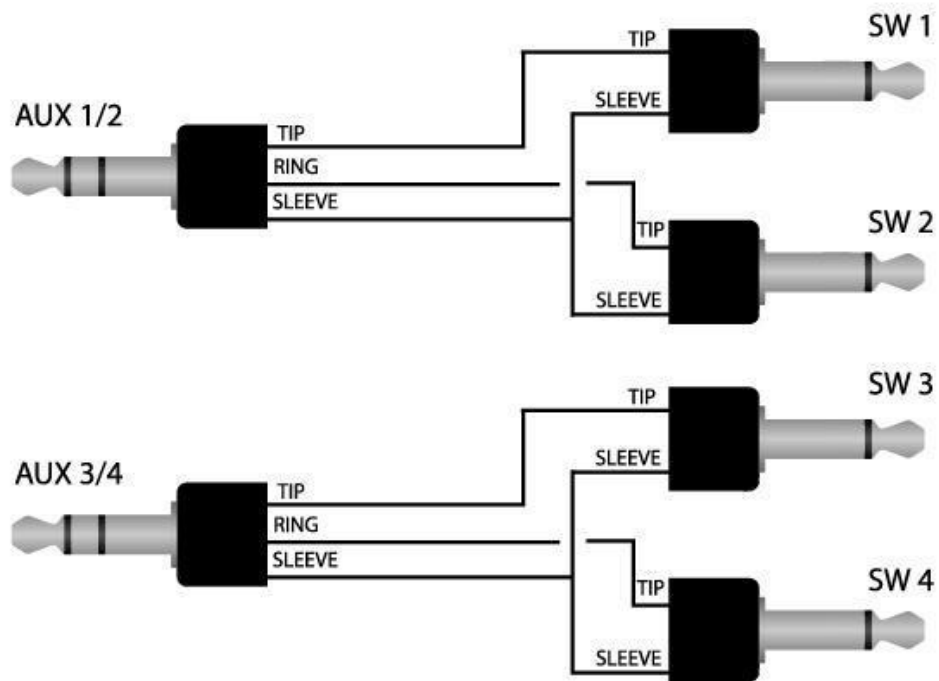

4.1.11. ISO Loop

There may occasionally be some ground loops causing hum, especially when using two amps or 4CM. The ISO loop features an isolation transformer between the ISO-IN and ISO-OUT connectors to reduce the effects of any ground loops.

4.1.12. EXP

NOTE: The TRS Cable MUST be connected before supplying power to the SmartSwitcher.

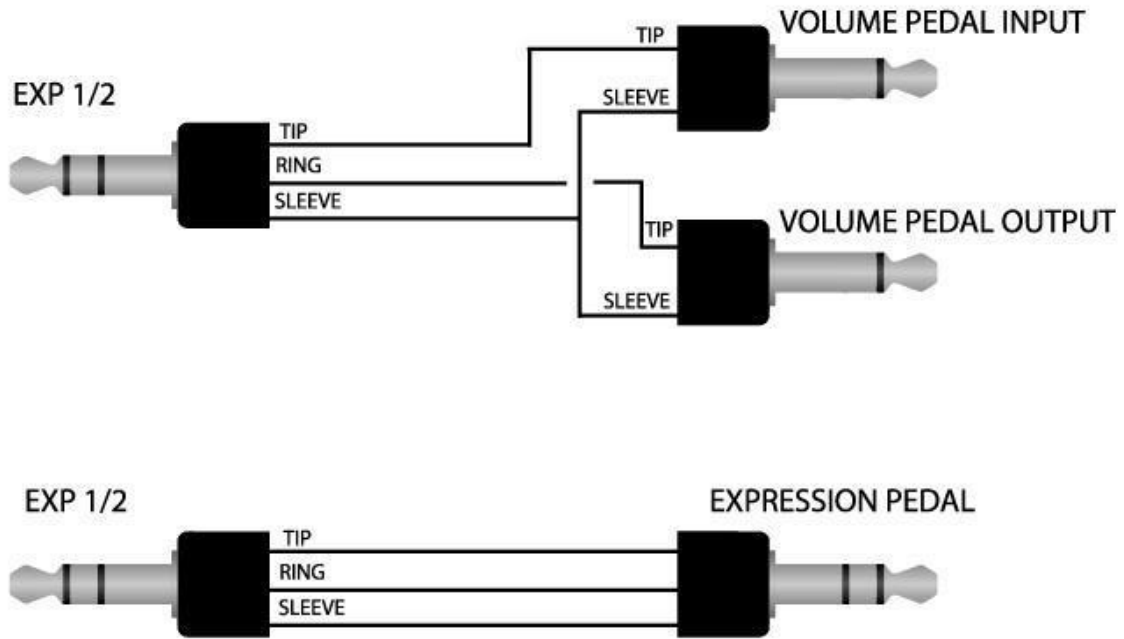

4.2.1 Wiring Diagrams

4CM for Wet Dry Wet setup

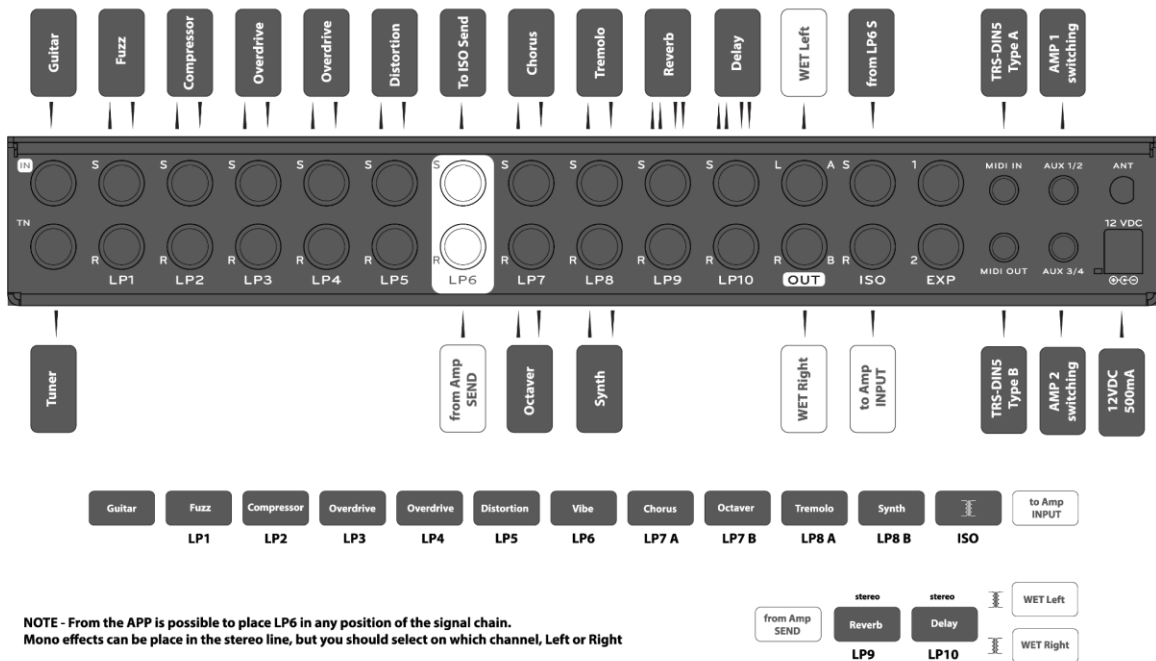

NOTE - From the APP is possible to place LP6 in any position of the signal chain. Mono effects can be placed in the stereo line, but you should select on which channel, Left or Right

MONO Connection - Two Amps option

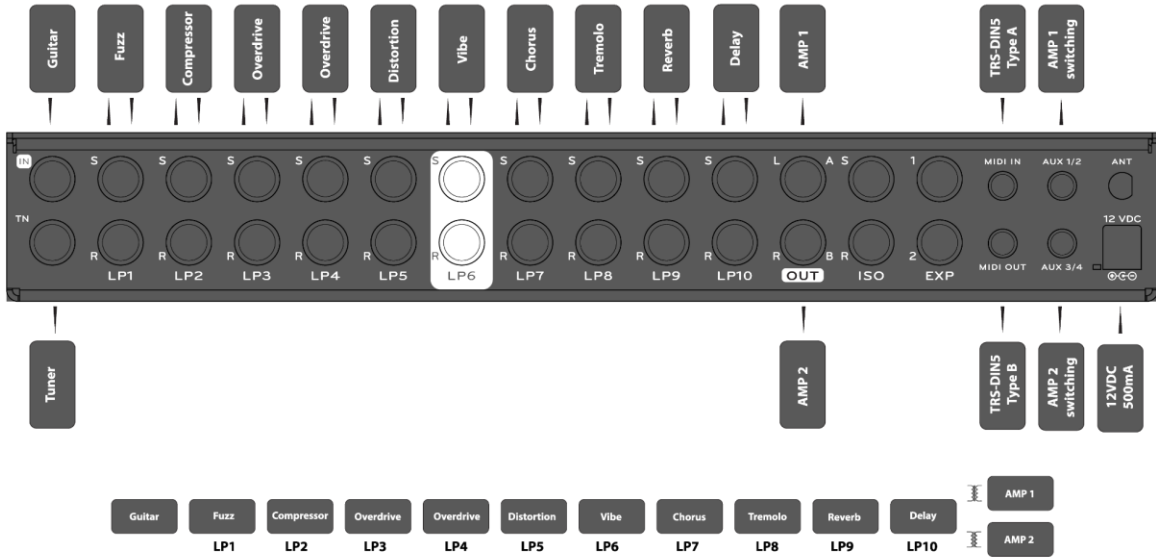

DUALMONO Connection - Two Amps option

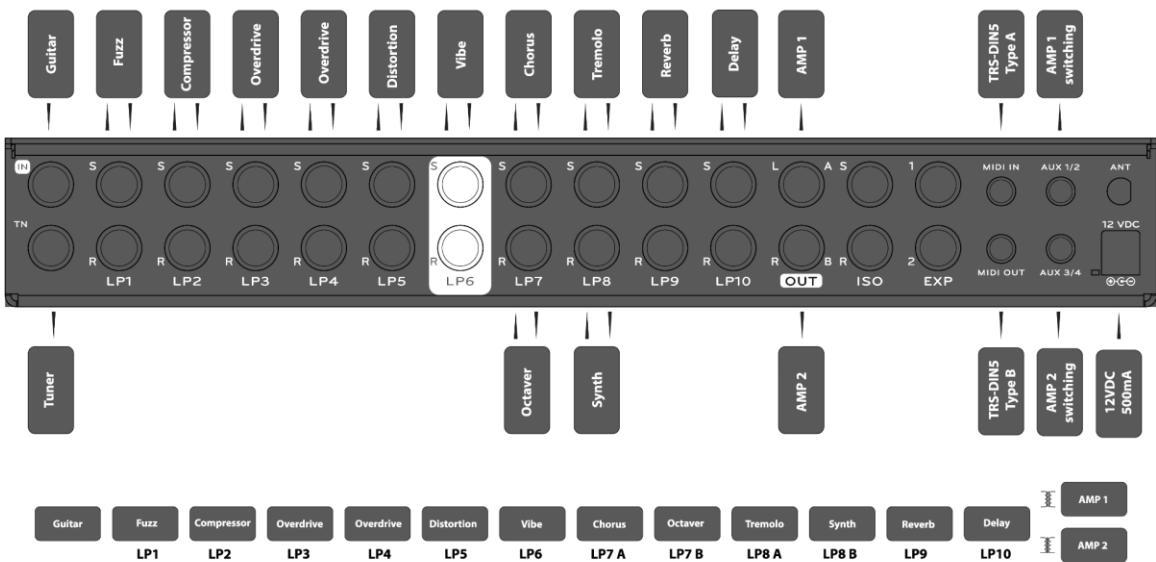

STEREO Connection - Two Amps option

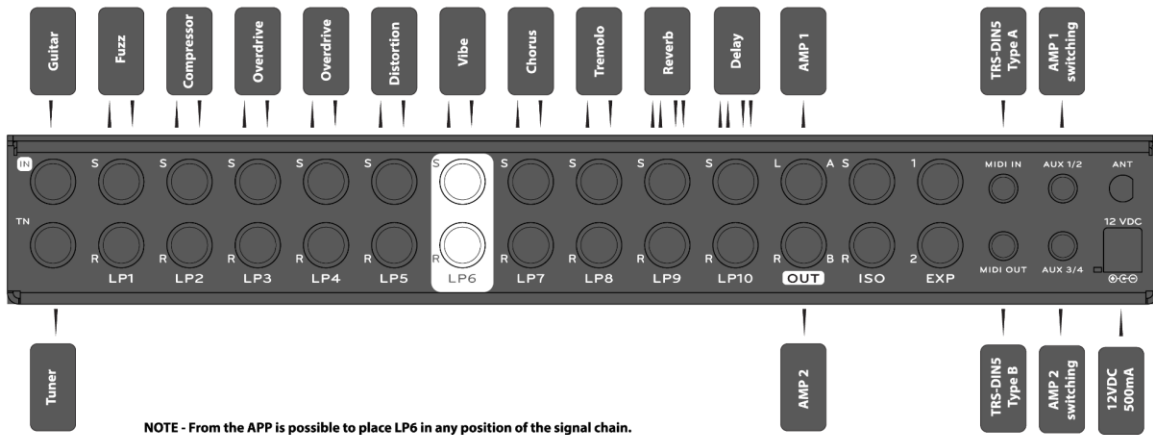

4CM with Dualmono option

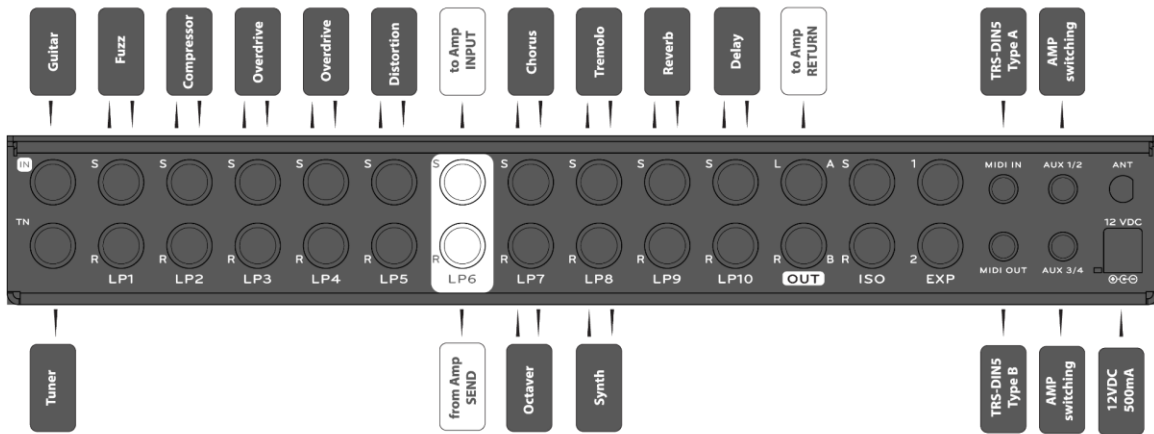

NOTE - From the APP is possible to place LP6 in any position of the signal chain.

5. Getting Started

5.1.1 Downloading the SonicMind® App

The SonicMind® App is available for iOS and Android and can be downloaded from Google Play Store or Apple’s AppStore. You can use the appropriate QR code below.



5.2.1 First Steps – Global Settings

Your first step should be to configure your system through Global Settings.

We recommend that you always make a backup of your presets before making any changes in the Global Settings, as some changes can lead to the loss of presets.

SmartController Mode

This enables you to select whether you have just the 5-switch SmartController, or whether you will use the additional 5 switches of the Extension unit.

Select either “**Controller (5 Footswitches)**” or “**Controller + Extension (10 Footswitches)**”. This will change the number of slots available in pedalboard set-up and programming.



RF Frequency

The SmartController and SmartSwitcher communicate with each other using Radio Frequency. Different regions/countries have different standards for the permitted “non-licensed” frequencies. To avoid any possible interference with other devices and to be compliant with local requirements, select the correct frequency for the area in which you will be using the equipment.

You have the choice of **869 MHz** (generally used for Europe), and **915 MHz** (generally used in the USA).

This setting can be changed without losing your programmed presets.

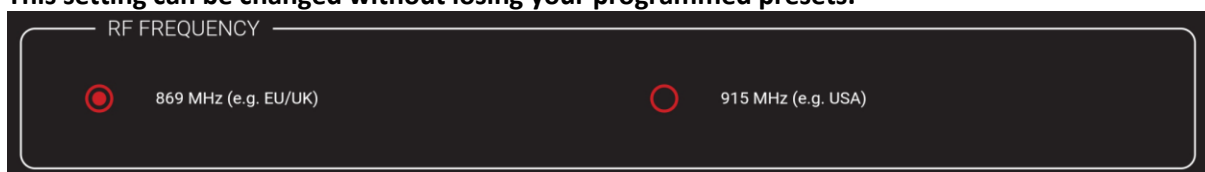

Pedalboard

This section is very important for the structure of your rig. It enables you to set up the various connections on your SmartSwitcher function.

First, you will need to connect your pedals to the SmartSwitcher. The order is not necessarily important, though we recommend you take note of the following points:

1. Connect any fuzz pedals to Loop 1 or 2 for optimum performance
2. Ensure that any stereo pedals are connected to Loops 7-10
3. If you intend to operate in 4CM using the amp's send/return, leave Loop 6 free for the amp

When you have connected all your pedals to your chosen terminals, you can then set the functions shown below and then enter their details into the App.

Please note, if you change something in this section, your presets will be deleted.

Loop 6 – use for Amp Send/Return

Enable this for 4CM wiring. Loop6 is buffered and can be moved to any position within the sequence during the process of creating presets.

Loop 9 / 10 – activate 1:1 mixer

If you have digital pedals with the option of enabling the “kill dry”, you can use them in parallel with the internal 1:1 mixer and keep the dry signal analog

Loop 7 / 8 / 9 / 10 mode

Select from Mono, Dual-Mono, or Stereo. Dual-Mono gives you the possibility of adding up to 4 more loops. The operation of these modes is given in Section [4.1.1 Mono / Dual-Mono / Stereo](#)

NOTE: You need to enable the stereo loops in order, from 10 to 7. Thus, if you connect only 2 stereo pedals, they should be on loops 10 and 9. You will see that only once Loop 10 is set to stereo, is the option to make Loop 9 stereo enabled, and so on for Loop 8 and then Loop 7.

PEDALBOARD

- Loop 6 – use for Amp Send/Return loop
- Loop 9 – activate 1:1 mixer
- Loop 10 – activate 1:1 mixer

Loop 10 Mode:	<input checked="" type="radio"/> Mono	<input type="radio"/> Dual Mono	<input type="radio"/> Stereo
Loop 9 Mode:	<input checked="" type="radio"/> Mono	<input type="radio"/> Dual Mono	<input type="radio"/> Stereo
Loop 8 Mode:	<input checked="" type="radio"/> Mono	<input type="radio"/> Dual Mono	<input type="radio"/> Stereo
Loop 7 Mode:	<input checked="" type="radio"/> Mono	<input type="radio"/> Dual Mono	<input type="radio"/> Stereo

AUX Switches

The SmartSwitcher has 4 AUX switches for external switching of amps or other gear. In this section, you can set the characteristics of each AUX:

Mode - Select between **Latch** (Stable ON/OFF), **Momentary** or **TAP Tempo**.

Timing - In **Momentary** mode you can select how long the on/off/on cycle is. You can adjust this from 5 to 50ms.

Polarity - Select from Normally-Open (Default) to Normally-Closed, this becomes the starting condition of the specific AUX. You should check the manual of the amp or pedals you want to drive with the AUX for more details.

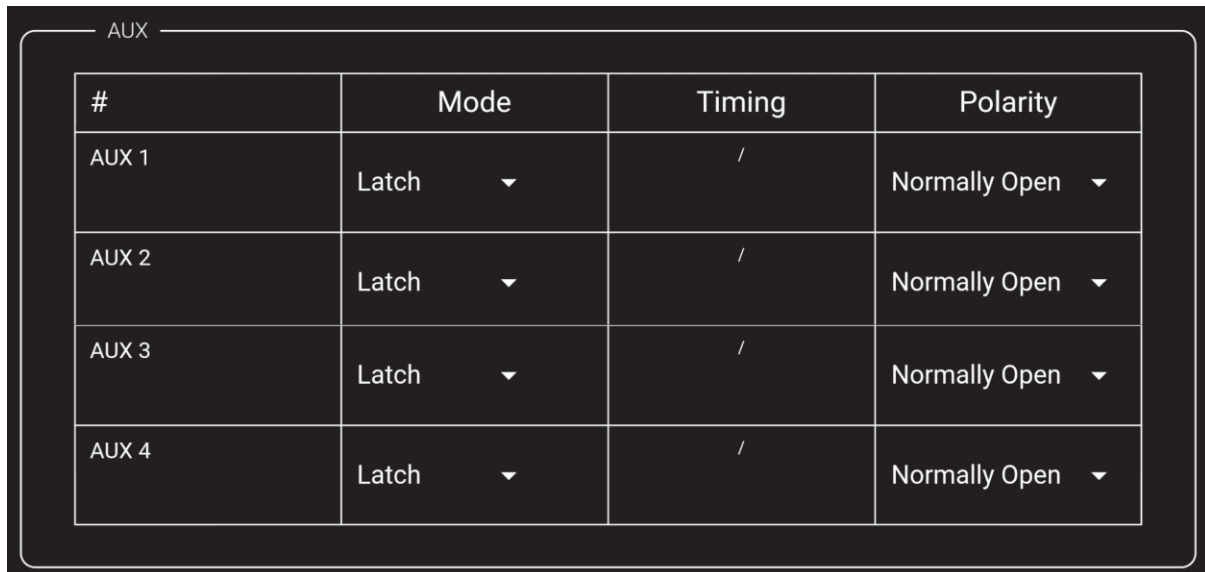

#	Mode	Timing	Polarity
AUX 1	Latch ▾	/	Normally Open ▾
AUX 2	Latch ▾	/	Normally Open ▾
AUX 3	Latch ▾	/	Normally Open ▾
AUX 4	Latch ▾	/	Normally Open ▾

Default Bypass State

You can set the output and the AUX state and which output (if you work in mono or Dual-Mono) when no presets are loaded. This basically creates an extra preset that we call Bypass. For example, if you want to have the crunch channel of your amp as a Bypass, you can set it with the AUX and don't need to create a dedicated preset. (For further details, see Section 5.1.2)

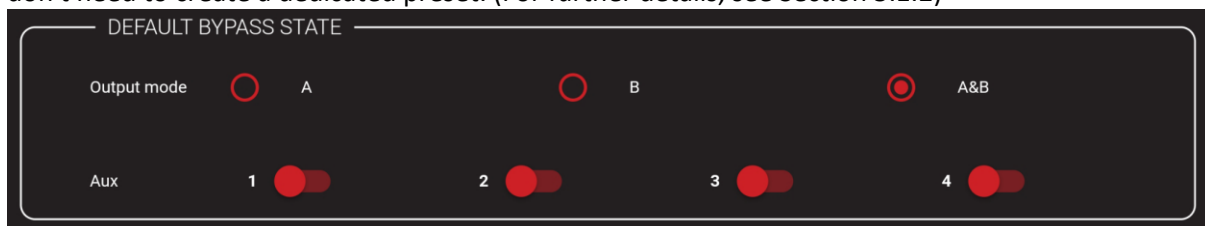

MIDI

This enables the MIDI IN and thus the possibility to drive the SmartSwitcher from an external MIDI controller. MIDI IN is received on all the channels. When MIDI IN is enabled, the MIDI LEARN button appears on the CREATE PRESET page.



5.3.1 Pedalboard Setup

From the Home Screen, simply choose “**SETUP PEDALBOARD**” from the “**PROGRAMMING**” block.

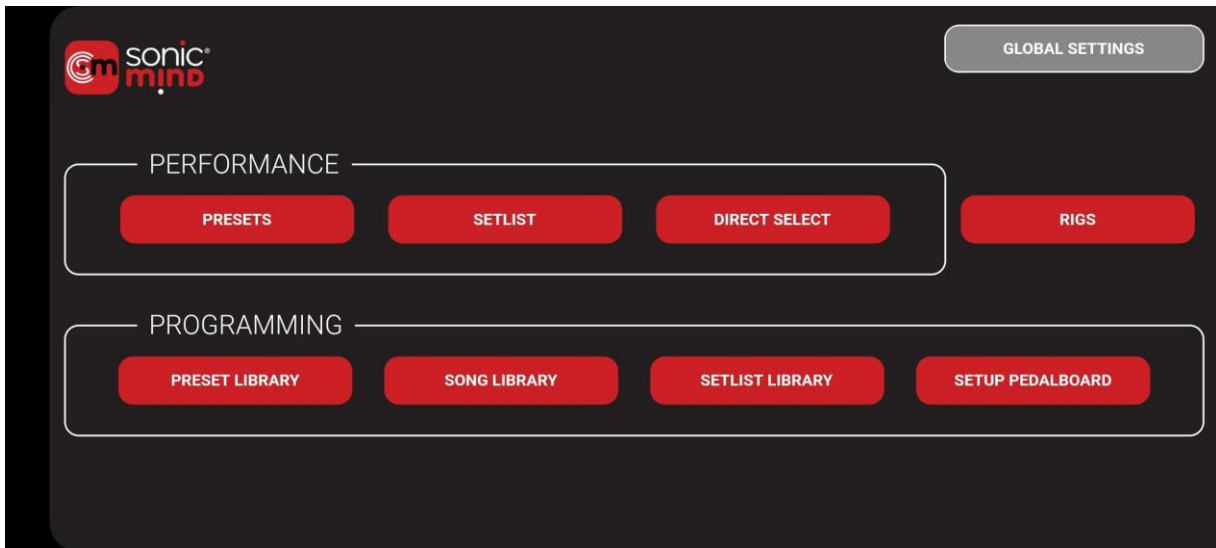

The **SETUP PEDALBOARD** page will open, and you will then see a representation of the connected loops. The number of loops here can vary based on your earlier setting choices (amp send/return, stereo/dual mono, etc. – see Section [4.1.1. Mono / Dual-Mono / Stereo](#)).

Here you can assign, for each loop of the SmartSwitcher, the details for the pedal you’ve connected. Press and hold on the relevant pedal icon to select these one by one to configure the relevant pedal.

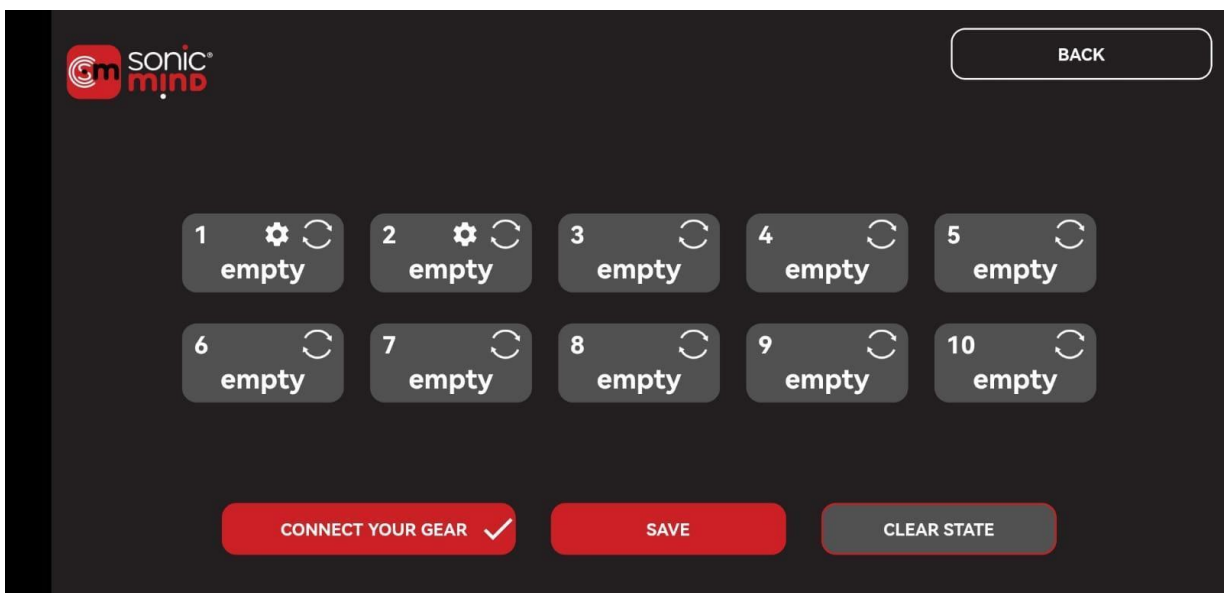

Note: Brief explanation of the icons within each loop:

Settings logo – this indicates that there are additional settings associated with this loop. When working in **PRESET** mode, press on this for approx. 1.5s and the screen with the associated settings will appear.

Circular logo – this indicates that the pedal can be moved to any position in the sequence. This is possible for all loops in the SmartSwitcher.

Press on the relevant loop and a new screen appears for that loop. You will have the following options:

1. Name of the pedal (whatever you like)
2. Color of the pedal (you can even make this close to the actual pedal's color, if you like).
3. If the pedal is a supported MIDI pedal, this can be selected from a list of supported MIDI pedals.

Press the red icon with the loop number in the top, left-hand corner and the keypad will appear. Use this to type in the name you want to assign to the pedal you have attached to this loop.

When you press the "Choose Color" button, you can then select the color you want from the palette.

For MIDI pedals, press the SELECT button and then choose the connected pedal from the list provided.

When you have made all the modifications you want, press save.

When you have completed this for all connected pedals, save your pedalboard – it should look something like this...

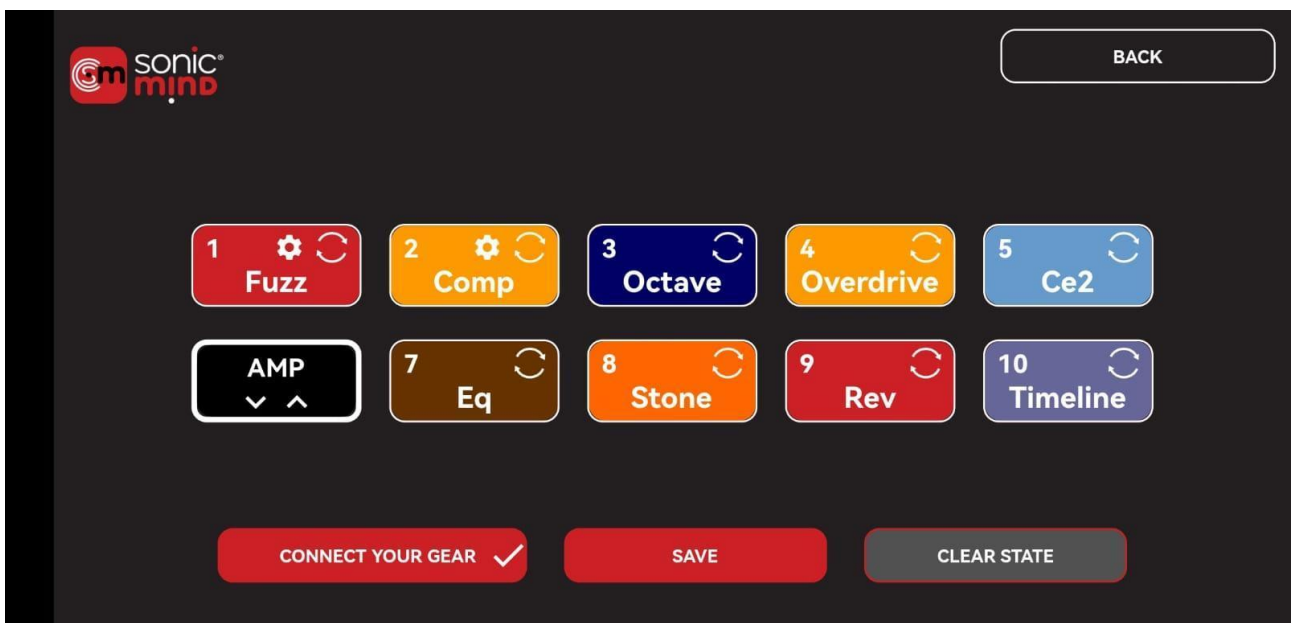

IMPORTANT!

In the bottom left of the SETUP PEDALBOARD screen, you will see the **CONNECT YOUR GEAR** button. This enables you to connect and pair your SmartController to the mobile device where you are running the app.

With Bluetooth activated on your mobile device and your SmartController switched on and nearby, you should see "sm_controller" as an available Bluetooth device.

Once the pairing is complete and the connection has stabilized, you will see the green "connected" message on the top of your screen. **You are now ready to get creative...**

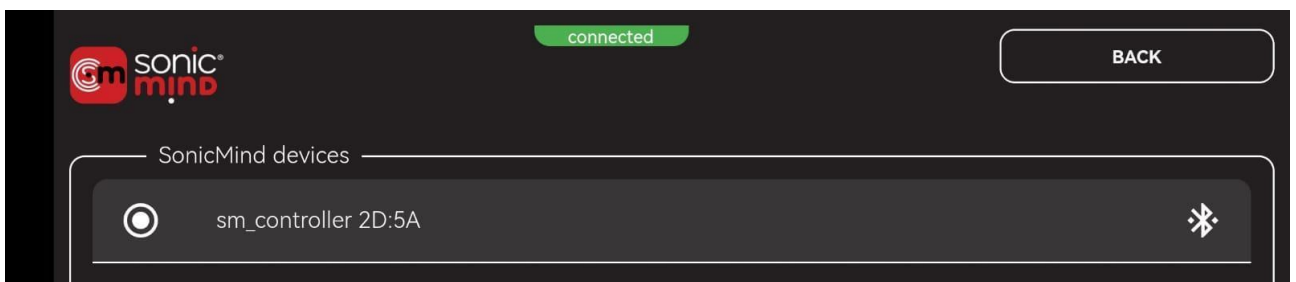

5.4.1 Programming - Preset Library

It is in the preset library where you can create all your different presets. Simply drag and drop the pedals to different positions, switch the amp channels, set the wet-dry, the boost and any of the other parameters to create your tones. Once you have a desired tone, simply give it a name (whatever you like) and save it. It's also where you can edit the presets you create.

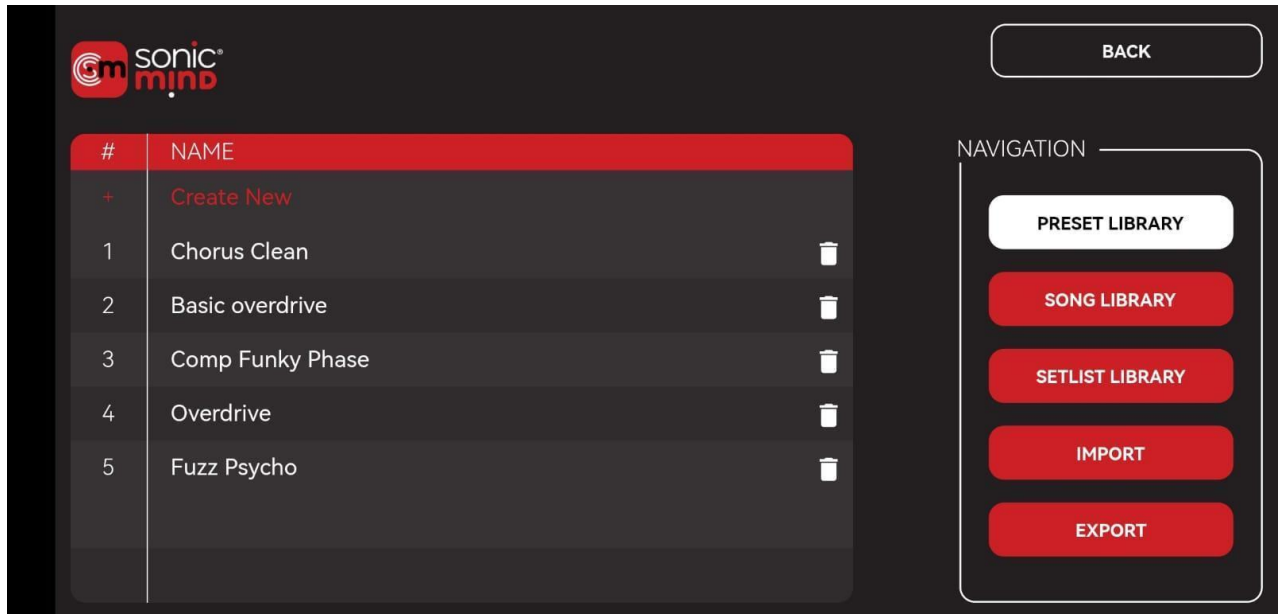

Creating a new preset

When you create a new preset, you can select which pedals are active, the order of them and additional options such as AUX switches, output level and MIDI settings.

When you tap "CREATE NEW", the **New Preset** screen opens.

Tapping the "NEW PRESET" label launches the keyboard and you can then give the preset whatever name you want. Enter the desired name and press **SAVE**.

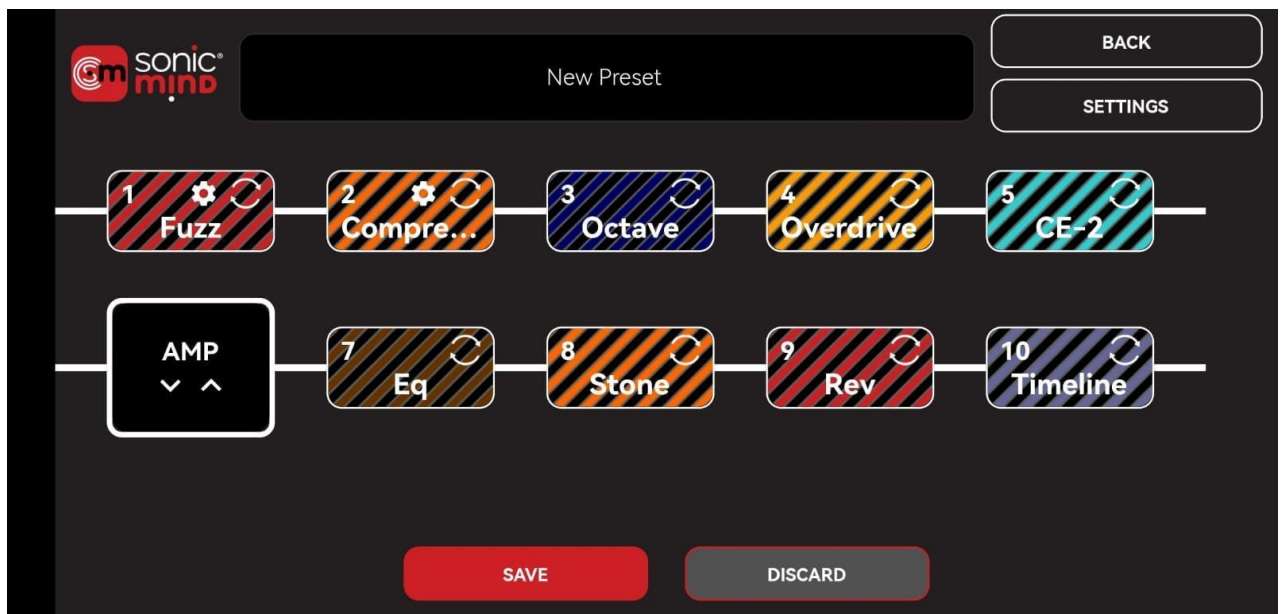

Then you can select the pedals you want to be active and choose where you want them in the signal path.

Tap on any pedal you want to be active and it will change from being striped to being a solid fill. To change the order, you simply drag and drop the pedal to where you want.

Note: If you drop the pedal BETWEEN two pedals, it is inserted between those 2 pedals. If you drag the pedal OVER another pedal, they swap places.

On Loop 1&2 you can also activate the **ADD DRY** option. Hold your finger on the selected loop (1 or 2) for about 1.5 seconds and the ADD DRY slider will appear for the selected loop.

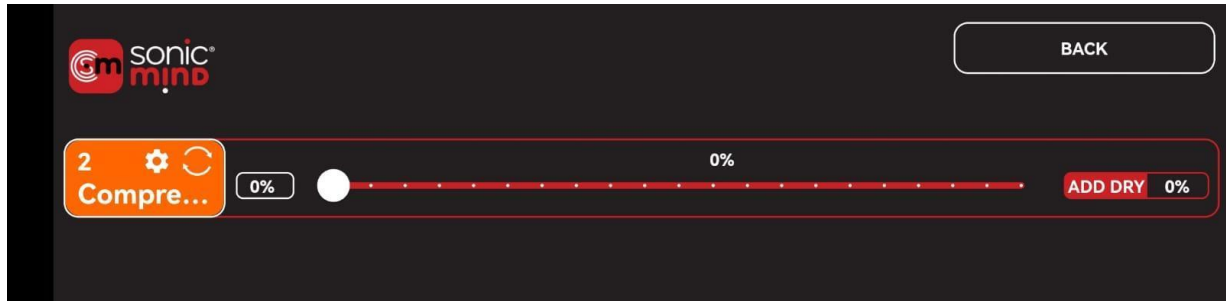

Moving the slider adjusts the percentage of Dry Signal in parallel with the active effect.

TIP 1 – Some effects may have the output signal out of phase relative to the input. In this case, adding a dry signal may create some unexpected sounds. To fix this, you can reverse the phase for the effects connected to Loop 1&2 using the switch on the front panel of the SmartSwitcher. Of course, you can always try it out of phase and get creative with your sounds!!

TIP 2 – On Loop 1&2 we added a high-impedance driver to help when using Fuzzes. A 3dB boost can be added from the front panel of SmartSwitcher for the best tone result. It is known that Fuzz pedals don't like too much buffer, and the SmartSwitcher's input is buffered. However, on Loops 1 & 2, the same circuit that is used in the Italian Wah has been added to simulate the high impedance of a pickup at the output. This works really well with Fuzzes.

Preset Settings

When creating a new or editing an existing preset, in the top right-hand corner of the preset overview page is the **SETTINGS** button. By pressing this, you will access a second layer of options for this preset. There are, in fact, 3 pages in the SETTINGS layer, which can be scrolled through by pressing the appropriate arrow next to the page number. Here you can set the OUTPUT or BOOST level, which AUX switch you want to be active, and on which output you will send the signal (if you are in mono).

TIP 3 – If you are using two amps, ground loops can be an issue. The SmartSwitcher uses custom output transformers on the output to avoid this, but in any case, you can adjust the two ground lift switches on the front panel of SmartSwitcher.

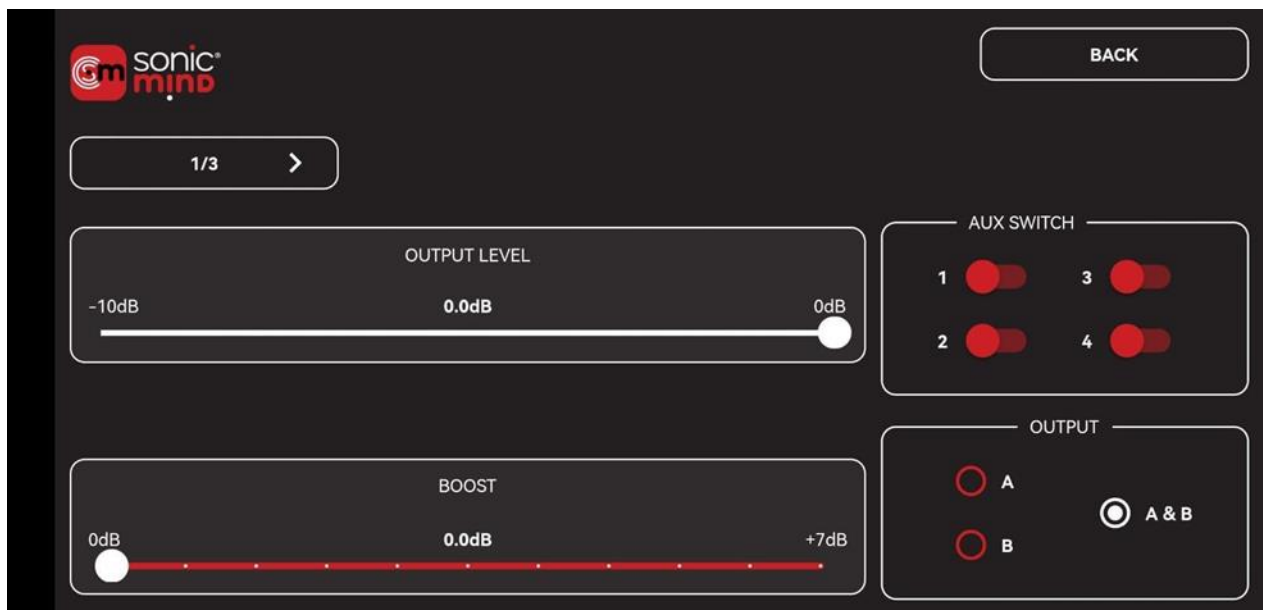

On pages 2 and 3 you can access the MIDI OUT mapping. These settings enable you to send Program Change and Control Change commands on different midi channels really easily.

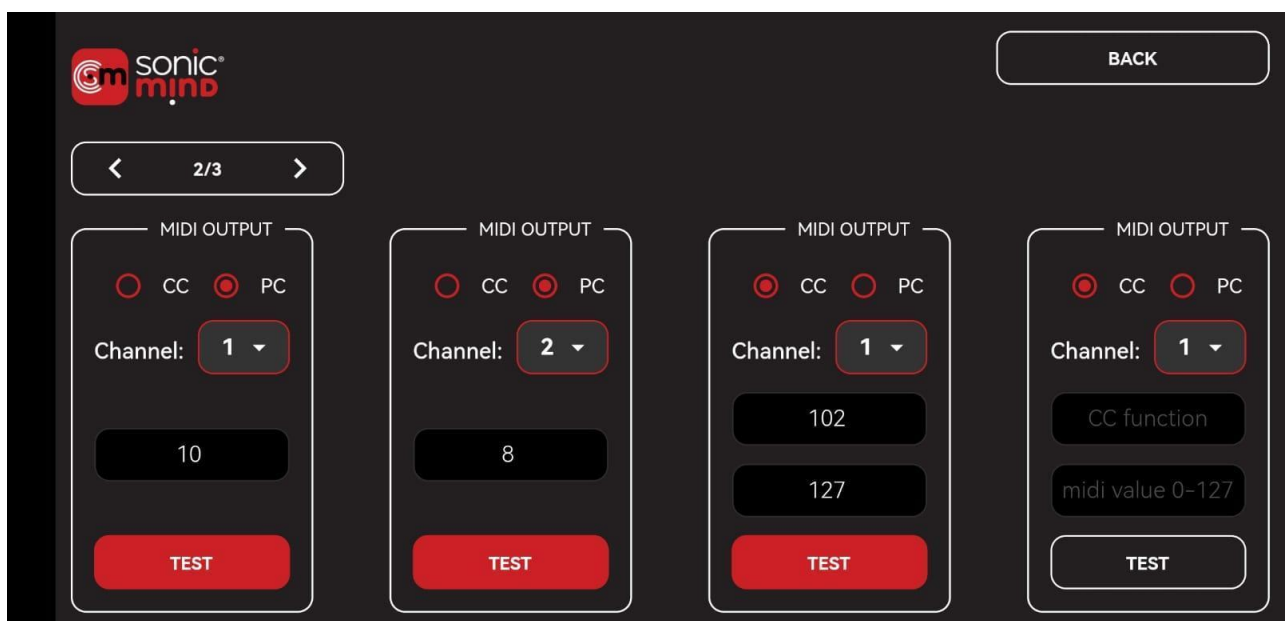

5.4.1. MIDI Pedals

If the pedal you have connected is a MIDI pedal and the MIDI ports are connected, then you have 2 options:

1. If the MIDI pedal is included in the library, you will have selected it from the library during “Setup Pedalboard” and a representation of the pedal will appear when you select it from the “Edit Preset” page. You will then be able to use the virtual knobs/switches on the pedal to select the required settings. Sometimes, since the pedal’s physical controls may be too close together, they will appear as sliders or other controls to the side of the pedal.
2. If the MIDI pedal isn’t yet included within the library, you will have the option to enter up to 8 MIDI commands (Program Change or Control Change) per preset on the pedal’s parameter page.

5.4.2. Editing Presets

Of course, you don't have to start each preset from a blank sheet – you can take a very similar preset, edit it as you like, then save it under a different name.

Once you have configured your presets, you'll end up with something like this:

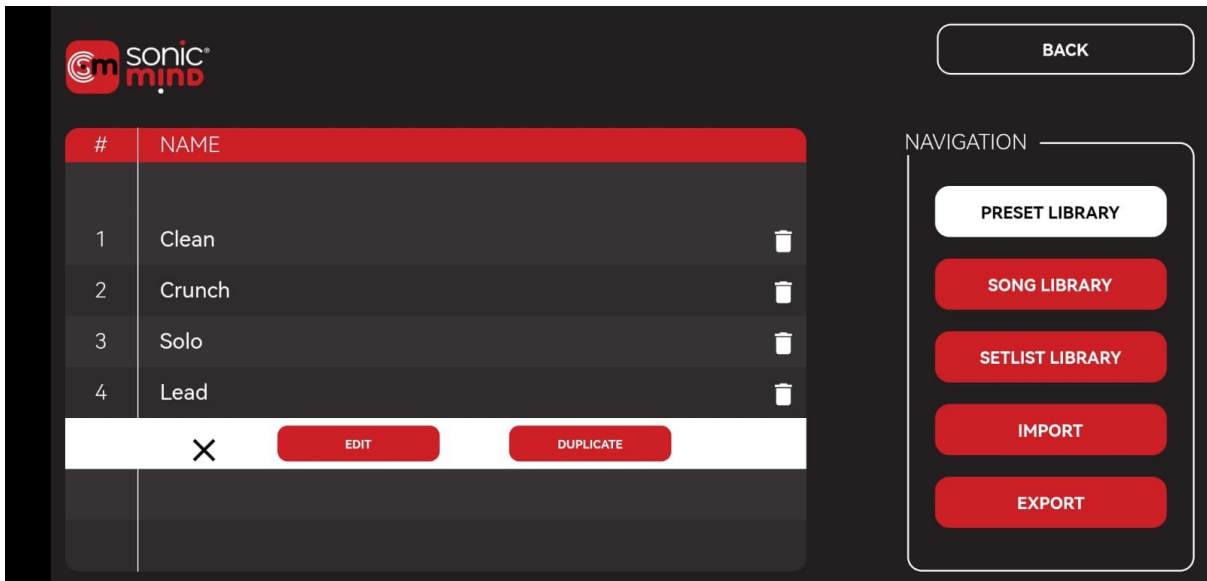

5.4.3. Song Library

Once you have a full library of presets, you can then build your songs as you like.

The process is similar to presets... simply give your song a name, and then drag the presets you want from the library into the part of the song where they're needed. Of course, you can use any preset any number of times in any number of songs!

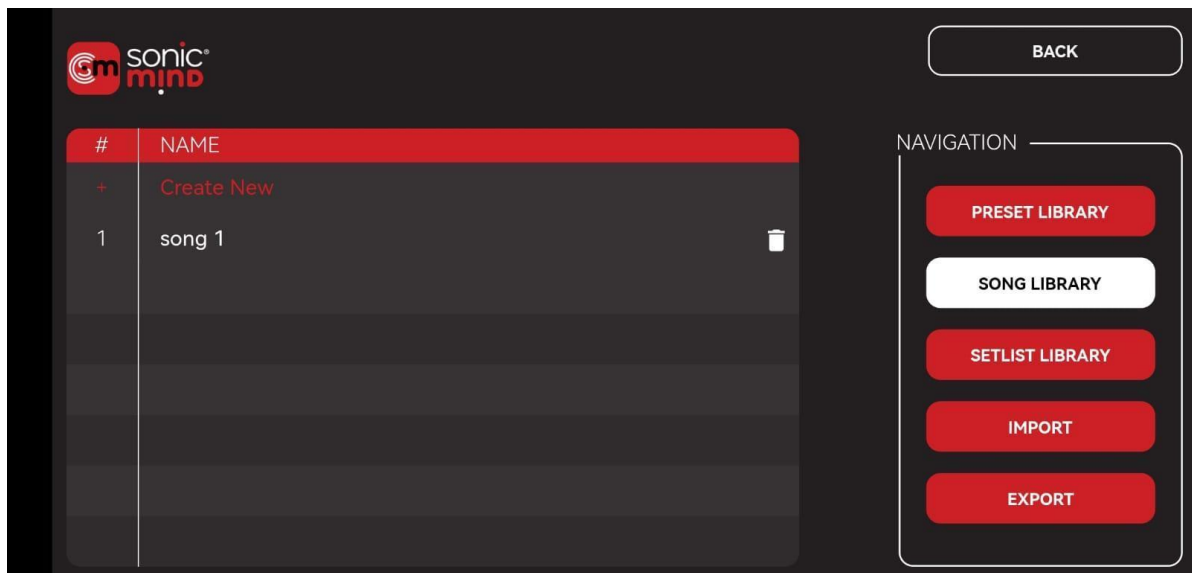

If you've inserted a preset into a song, but then decide you want to alter that preset within that particular song... then you can. The changes are saved ONLY for that song (unless you decide to save that preset as a completely new preset). You can also rename presets used in a song as you like! It is very useful to name the presets according to the song parts, for example: introduction, verse, chorus, solo...

5.4.4. Setlist Library

You now have a bunch of presets arranged into songs. Now, you build your set-lists in the same way. Just drag and drop the songs into the order you want.

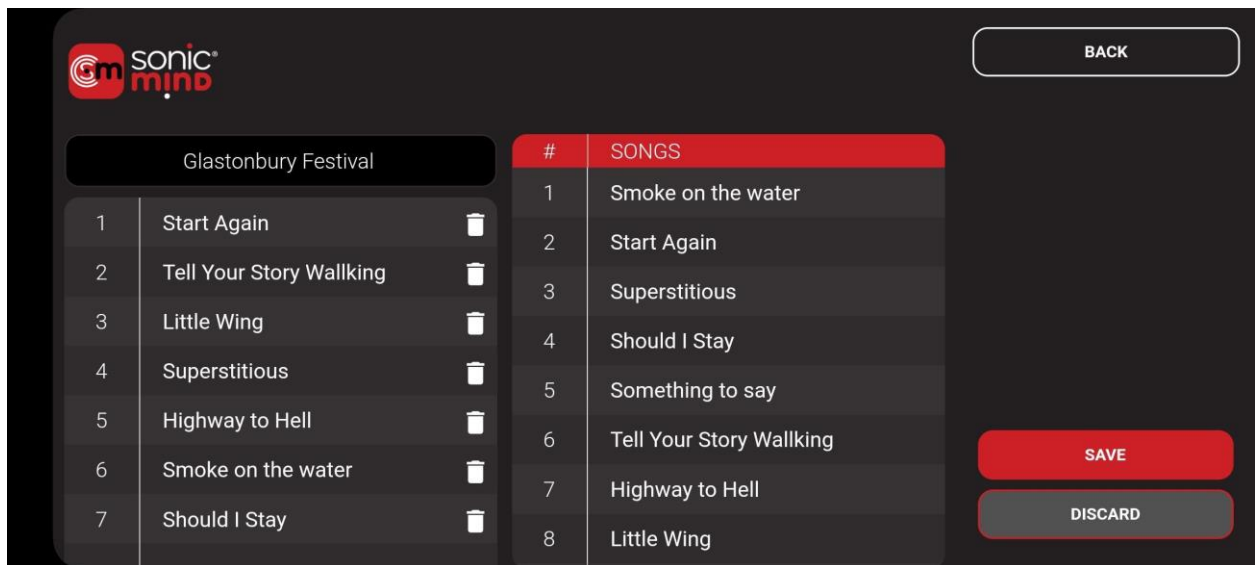

6. Performance Modes

Everybody likes to use their switchers differently, and the LAA Custom SmartSwitcher and the SonicMind® app have been designed to ensure maximum flexibility with three performance modes available:

Preset – Direct access to your presets using the SmartController footswitches (and extension unit footswitches too!). All footswitches can operate with banks.

Setlist – Using just three footswitches on the SmartController, you can scroll through each section of each song in your selected set list, or even jump forward and back - sections and songs.

Direct Select – Very useful in the studio or during jam sessions, you have direct access to your pedals like in a standard pedalboard, but you can switch each pedal in or out by the easily accessible footswitch on the SmartController (and extension if needed) that has been assigned to that pedal.

6.1.1 Presets

In this mode, you are able to assign multiple presets to each footswitch. In addition, several ACTIONS (specific functions and settings) can also be assigned to footswitches, which are activated on the currently-selected preset.

You can also assign up to 4 banks with different colors for each. For each available footswitch (A - D for the 5-switch configuration, A - J for the 10-switch configuration), four banks are shown.

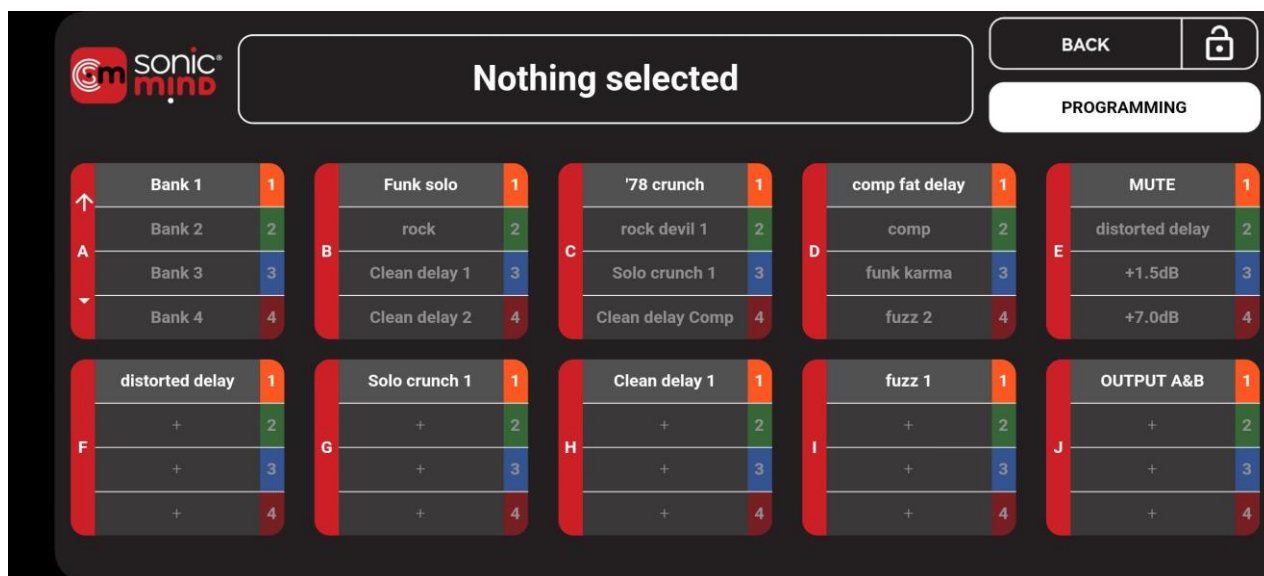

PROGRAMMING

To assign a preset or action to a footswitch & bank position, select **PROGRAMMING** at the top right-hand corner of the **PRESET** mode screen. Then click on the + symbol in the footswitch/bank slot you want to change - the list of presets is displayed on the first page of 2. Then you can simply select the preset you wish to assign, and press **SAVE**.

To assign an **ACTION**, click on the + symbol in the footswitch/bank slot you want to change, then select **screen 2/2**. Here you will see all available functions displayed and you can select (or set the sliders) to define the **ACTION** you wish to assign. Then press **SAVE**.

The additional functions that can be assigned to footswitches are:

- Output Level (-10 to 0dB)
- Boost (0 to +7dB)
- Mute
- AUX switching

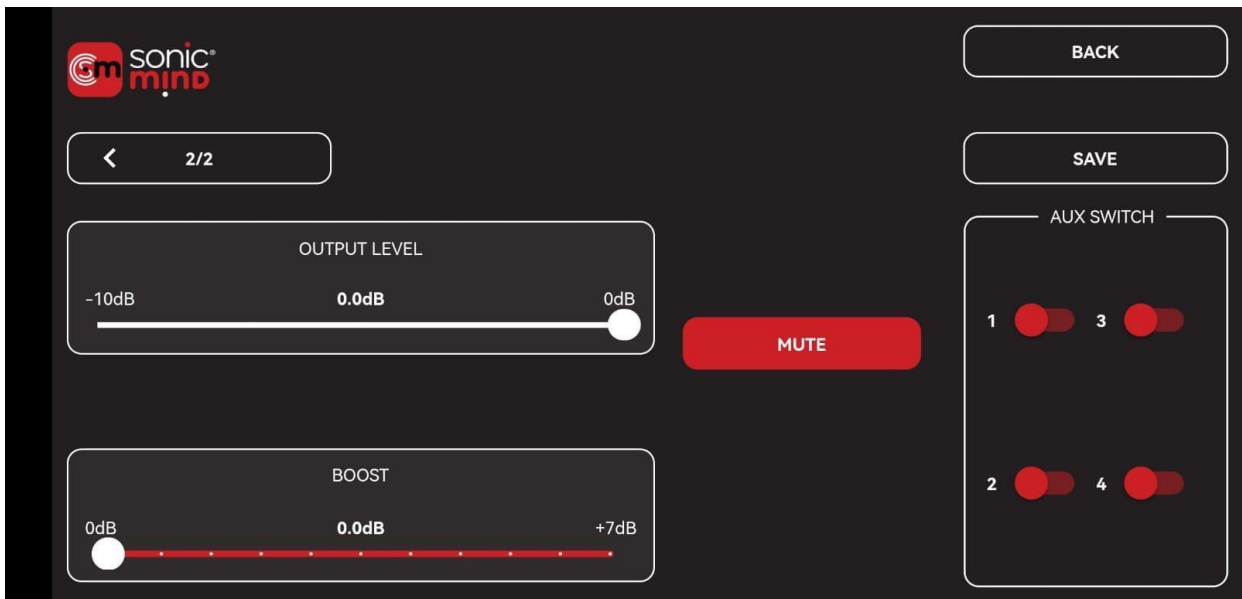

PLAYING

Footswitch A is used to select the required **bank**, with all other available footswitches used in whatever way you wish. This is reflected in the on-screen display. **Short press will move on the next bank, long press will move on the previous bank.**

As you bank up or down, the currently-selected preset remains unchanged UNTIL you select a new preset from the selected bank. In the same way, if you are selecting an output boost from one bank while a preset from another bank is selected, the boost will be applied to the current preset, irrespective of bank.

The user interface on the App has been optimized in order to make it as clear as possible to see where you are at any time and where you are going.

When you select a **PRESET**, its name is shown clearly on the top of the screen with the relevant bank color as the background. If you select an **ACTION**, it will be shown to the right of the selected preset.

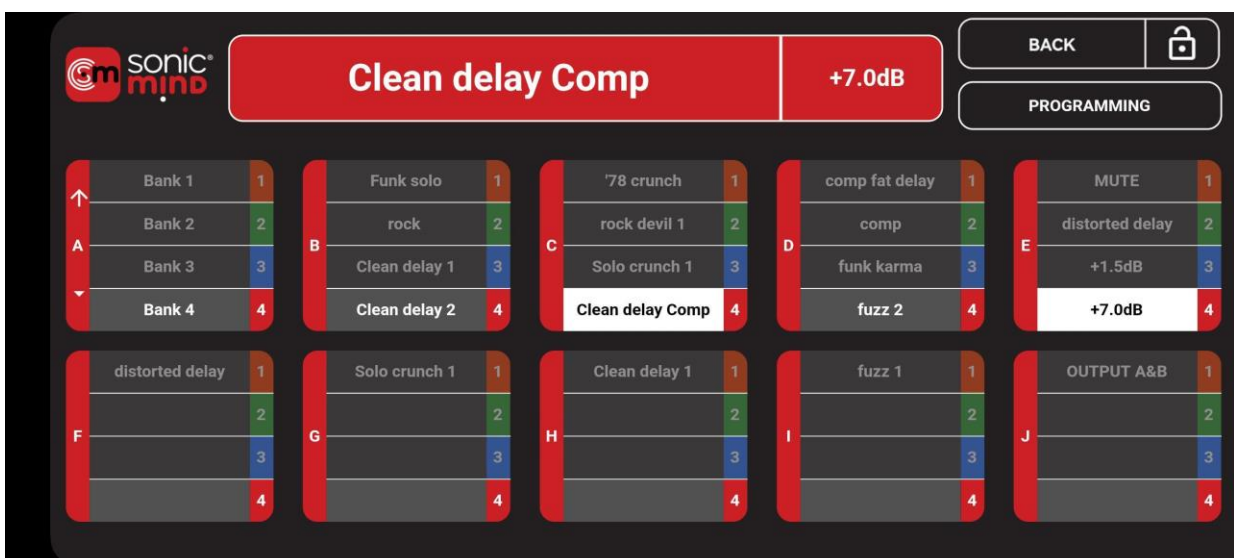

BYPASS STATE

If you press the footswitch on the SmartController to turn the current preset OFF the BYPASS is activated. Bypass means that all the loops on SmartSwitcher are off and the routing signal will simply follow the 4CM logic (if enabled in Global Settings). It will also follow the Default Bypass State for the routing on the output (if in mono) and the AUX switches as you set in the Global Settings. If your Bypass is on the light crunch channel of your amp, you can set it with the relevant AUX. You don't need to create a dedicated preset, but you will be always able to reach your bypass by simply disabling the currently-loaded preset.

6.2.1 Setlist

When you are playing in **SETLIST** mode, you can simply press the one footswitch to scroll through the song – easily moving on to the next section with each tap.

When you reach the end of the song, just keep tapping and you step seamlessly into the next song.

It is also possible to go back and repeat any part of the song, or skip one song/go back one song.

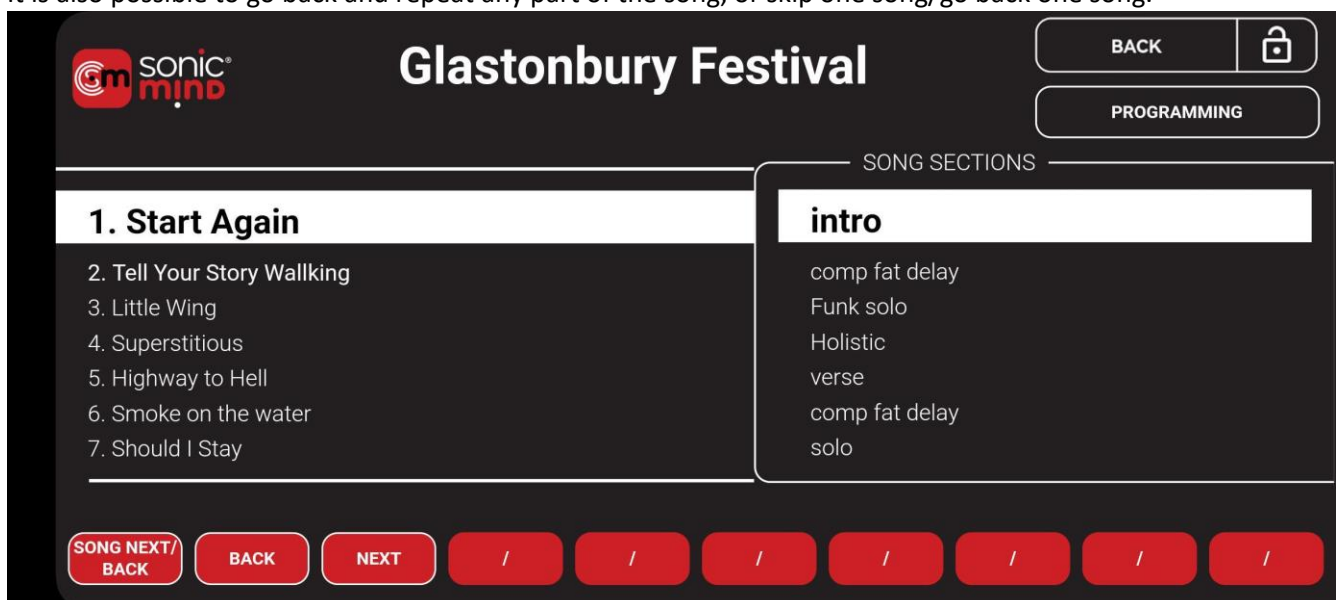

The function of each footswitch is shown on the 5 buttons at the bottom of the screen (or 10 buttons if you are using the Extension unit).

When you are playing in **SETLIST** mode, you can simply press **NEXT** (footswitch C) to scroll through the song – easily moving on to the next section with each tap. When you reach the end of the song, just keep tapping and you step seamlessly into the next song.

If you need to go back and repeat any part of the song, tap **BACK** (footswitch B) to get you back to the part you need. Likewise, a standard press of **SONG NEXT/SONG BACK** (footswitch A) skips to the next song, a long press (approx. 0.5 secs) takes you back one song.

All the time, the visual display from the app shows you exactly where you are within each song and within the whole setlist.

6.3.1 Setlist – Customizing Additional Footswitches

Note that at the bottom of the display, you have 5 buttons (10 with the Extension) – these are mapped to the footswitches on the SmartController. The defaults of SONG NEXT / BACK, BACK and NEXT are configured as standard for the **SETLIST** performance mode, with the option to customize footswitches D & E (and F-J if extension is connected).

To program these switches, select the **PROGRAMMING** button in the top right-hand of the screen. You will then be able to add the desired **ACTIONS** to the spare buttons.

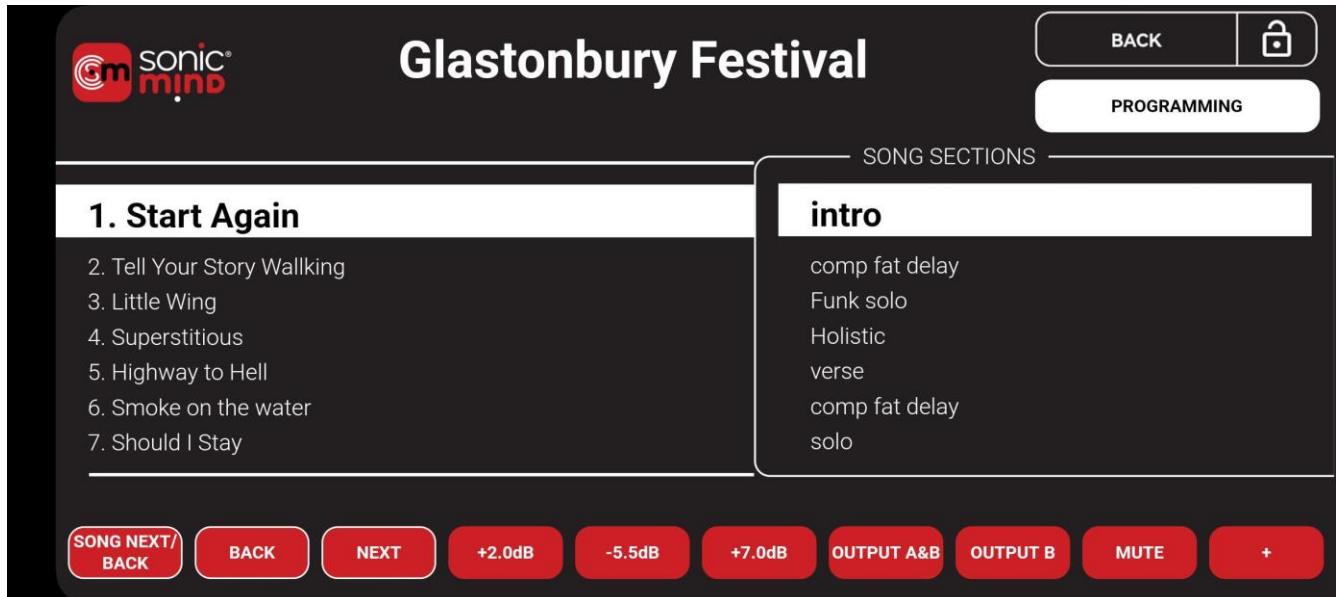

6.4.1 Direct Select

This enables you to be “old school”. If you want to operate in a traditional stompbox mode, where, rather than having to step on individual pedals on your board to switch them in and out, you can assign each pedal to one of the footswitches and simply stomp on your SmartController (easier than dancing over the whole pedalboard!).

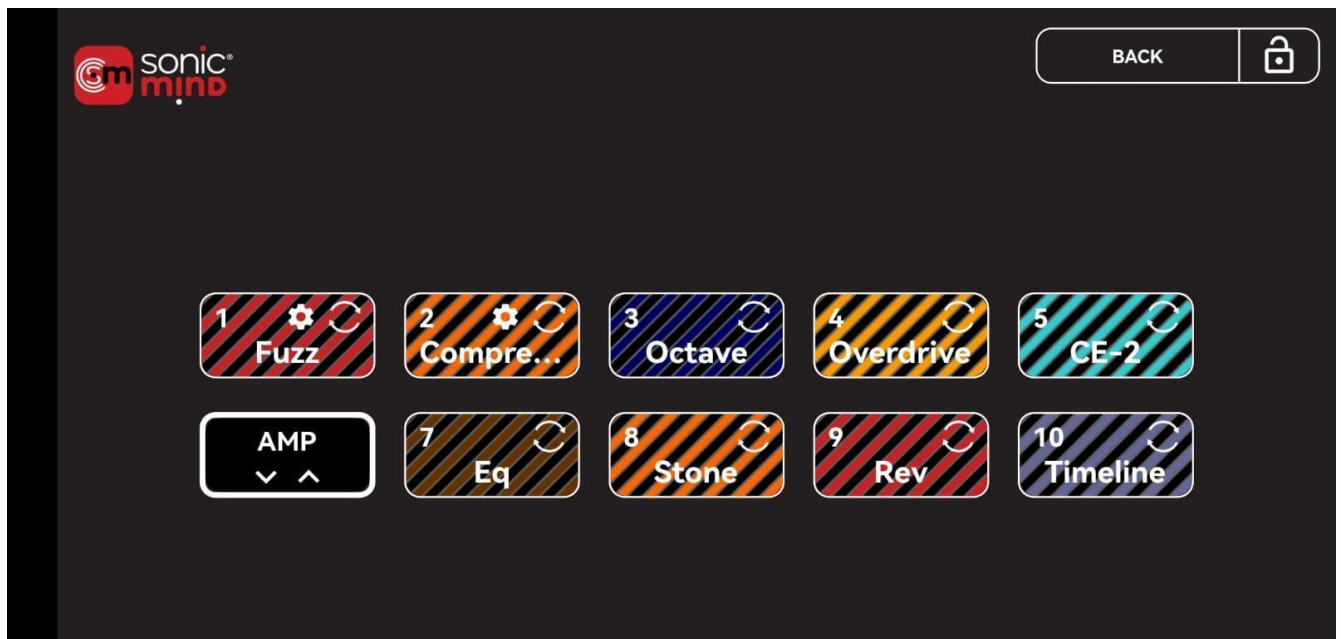

In DIRECT SELECT mode you will be able to activate loops directly, with them in the order and sequence they are connected to the SmartSwitcher loops.

Using the SmartController and extension foot switch you will be able to access up to ten loops directly.

NOTE: since the current number of connected footswitches is limited to 10 (Controller + extension), it is not possible to operate in Direct Select mode when using Dual-Mono mode on any loops.

Use this mode during a jam session or in a studio as if your pedals were in a standard pedalboard, but without any of the usual signal loss.

7. Care and Maintenance

7.1.1 Maintenance and cleaning

The SmartSwitcher has been designed using the highest-quality components and does not require any specific maintenance.

So long as the SmartSwitcher is handled properly, the only possible wear parts are the footswitches and we expect those to have a lifetime of several years.

As with any electrical equipment, you should avoid spilling any liquid on it.

To clean any of the items (SmartSwitcher, SmartController, extension), we recommend wiping it down carefully with a damp cloth. Do not use any alcohol-based cleaners.

7.2.1 Changing batteries in SmartController

The life of the rechargeable batteries supplied with your SmartSwitcher is expected to be between 3-4 years of normal usage. If, for some reason, the batteries DO need changing, any commercially-available 1.5V AAA batteries can be used. The batteries are accessed by undoing the Allen-head screws on the bottom of the SmartController and then carefully separating the 2 parts.

NOTE: the 2 parts of the SmartController MUST be separated carefully and slowly in order that the internal connection for the antenna is not stressed.

7.3.1 Returns

In the event that the SmartController needs to be returned for any repairs, please pack it carefully in its original packaging and send it to the following address:

LAA Custom

Via Nicola Porpora 7

10155 Torino - Italy

Please also inform us via e-mail once you have sent the unit (info@laa-custom.com).

We recommend sending all elements (SmartSwitcher, SmartController, extension) to ensure we can troubleshoot your problem fully.

While your SonicMind App is effectively the master for all your SmartSwitcher settings, so you won't risk losing any settings, presets or data during repair, we also recommend making regular backups of the app.

8. Specifications

SmartSwitcher

Dimensions: 300 x 100 x 44 mm / 11.811 x 3.937 x 1.732 inch

Weight: 1,556 kg

Power supply needed: 12V DC @ 500mA

Input impedance: 1 Mohm

Output impedance: 600 ohm

Nominal max signal amplitude: 3 Vpk

SmartController

Dimensions: 300 x 66 x 35 mm / 11.811 x 2.598 x 1.378 inch

Weight: 0,972 kg

Power supply needed: 9V DC @ 300mA

Batteries: 6 x AAA 1.5V, rechargeable or non-rechargeable batteries

Note: Use non-rechargeable batteries only in emergencies, and in such cases, do NOT use a power supply!

Extension

Dimensions: 300 x 66 x 35 mm / 11.811 x 2.598 x 1.378 inch

Weight: 0,882 kg

9. Safety Notices

9.1.1 Warranty

All products manufactured by LAA Custom are warranted to be free of defects in workmanship and materials for a period of one year from the date of shipment. If any statutory warranty periods exist in the buyer's country, LAA Custom will honor that warranty period.

In the unlikely event of a failure, LAA Custom will not be held responsible or compensate for any loss of earnings or any other losses incurred as a result of the failure or malfunction of this equipment.

If any defect in workmanship or material should develop under conditions of normal use and service within the warranty period, repairs will be made at no charge to the original purchaser, upon delivery of the product(s) to the address given in Chapter XX.XX.X "Returns". Shipping charges incurred returning goods to LAA Custom shall be paid by the customer.

If inspection by LAA Custom or its authorized representative reveals that the product was damaged by accident, alteration, misuse, abuse, faulty installation or other causes beyond the control of LAA Custom, this warranty will not apply.

Service, repairs or disassembly of the product in any manner, performed without the specific factory permission, voids this warranty. The exception to this is the SmartController unit, where the occasional separation of the top and bottom parts is required for changing the batteries. This should be carried out in line with the instructions in this manual or any additional official LAA Custom materials. However, if there is evidence that the battery replacement has been carried out improperly, the warranty will also be void.

NOTE: The product specifications and other information contained in this manual are subject to change without notice.

We make all efforts to provide complete and current information for the proper use of the equipment, and the latest version of the manual will always be found at www.laa-custom/manuals. If there are questions regarding this manual or the proper use of the equipment, please contact LAA Custom at:

LAA Custom
Via Nicola Porpora 7
10155 Torino - Italy
Email: info@laa-custom.com

9.2.1 Disposal

If you need to dispose of this equipment, its components or packaging materials, ensure that you do so in an environmentally compatible way and in accordance with your country-specific waste disposal regulations. Do not dispose of electrical equipment in household waste!

9.3.1 Safety

The SmartSwitcher contains no fixed batteries and is RoHs compliant.

The SmartSwitcher has been designed in line with sound engineering practices and risk assessment and is thus compliant with the EN 62368 safety standard.